

POLARO XL Standard

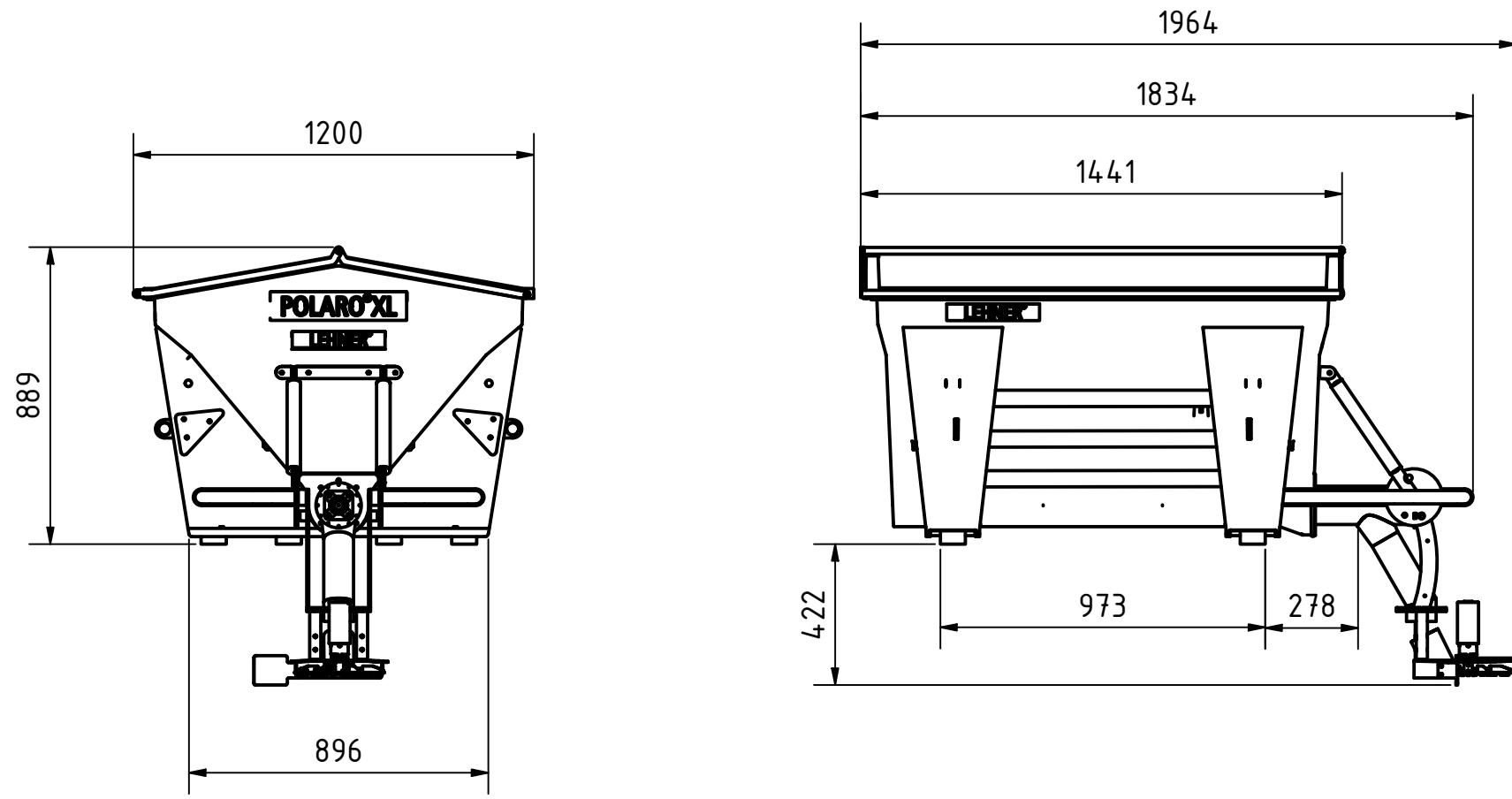

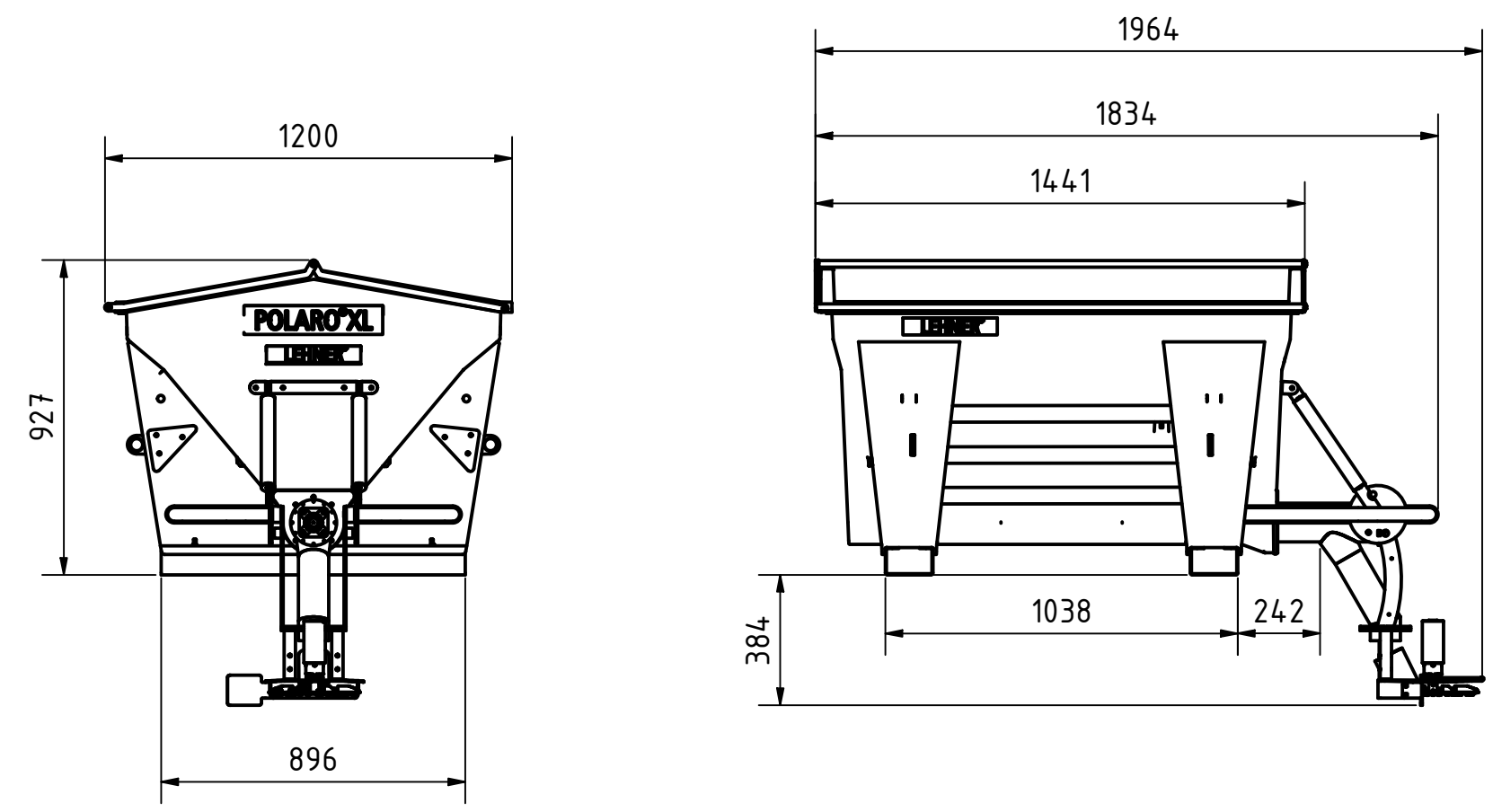

POLARO XL mit Staplerschuhe
"optional"

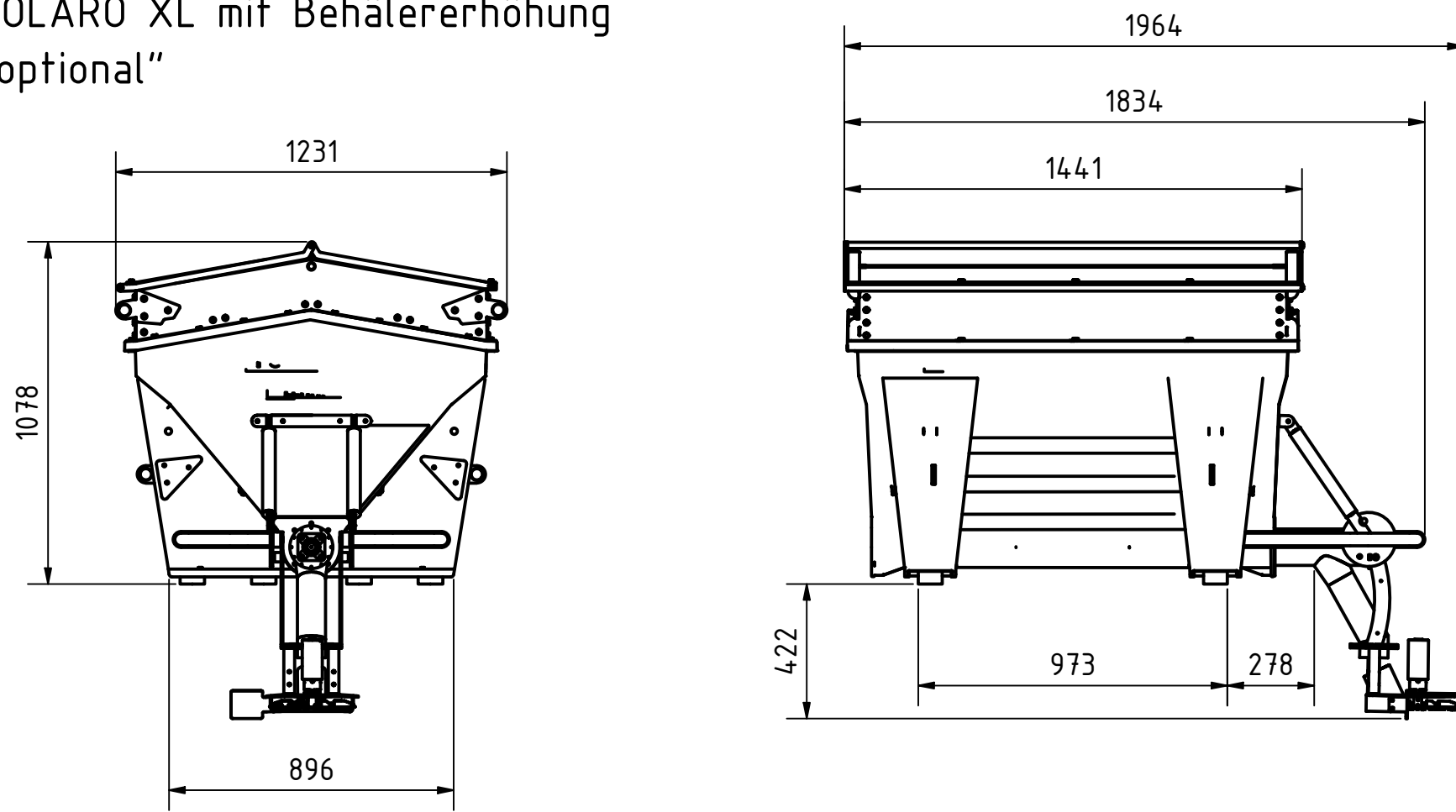

POLARO XL mit Behältererhöhung
"optional"



Sonstige Bemerkungen Additional Notes				 LEHNER Streuen & Dosieren mit 12 Volt		Artikel Nr. Article No.	73206	XXX Status/Revision	
				Datum Date 01.03.2024 Name Winkler		Titel Title POLARO XL Abmaße			
				Gezeichnet Drawn					
				Kontrolliert Checked					
				Freigabe Approved					
				Material Material					
				Bemerkung Material Material Note					
				Beschichtung Surface Coating					
				Beschichtungsdicke Layer Thickness					
Status Revision	Anderungen Description	Datum Date	Name Name			Toleranz Tolerance	Projektion Projection	Maßstab/Scale 1 : 20	Blatt/Sheet 1 / 1
						DIN ISO 2768 mK ISO 4063		Gewicht/Weight -	Größe A2
						DIN ISO 128-30		*Alle Maße sind in mm angegeben. *All dimensions are in mm.	