

# LEHNER



## POLARO® E

### Operating instructions with spare parts list

Control LAS 4  
Software from version 3.3  
Status: January 2019

Serial number: .....

Software version: .....

**Original operating  
instructions**



**LEHNER Maschinenbau GmbH**

Haeuslesaecker 14

D-89198 Westerstetten, Germany

Tel.: +49 7348 9596-22

Fax: +49 7348 9596-40

[www.lehner.eu](http://www.lehner.eu)

[info@lehner.eu](mailto:info@lehner.eu)

This document may not be distributed, duplicated or utilised, nor may its content be communicated without express permission. Compensation will be sought for all breaches. All rights reserved in the event of patent, utility model or design registration.

**English**

# Table of contents

## Contents

<b>1</b>	<b>What you should know</b>	<b>6</b>
1.1	Foreword	6
1.2	About these operating instructions	6
1.3	Description of the POLARO® E	7
1.4	Intended use	9
1.5	Reasonably predictable misuse	9
1.6	Warranty	9
1.7	About your safety	10
<b>2</b>	<b>Mounting and starting</b>	<b>11</b>
2.1	Installing the frame	11
2.2	Mounting the hopper and deflector plate	12
2.3	Electrical connection	13
2.4	Filling the spreading material hopper	14
<b>3</b>	<b>Operating the POLARO® E</b>	<b>15</b>
3.1	Controls on the control console	15
3.2	Indicators in the display	16
3.3	Switching the spreading disc and agitator on and off	17
3.4	Setting the speed	19
3.5	Setting the slide opening	19
3.6	Opening/closing the slide	20
3.7	Setting the working width	21
3.8	Setting the spreading zone	22
3.9	Empty sensor	22
3.10	Calibrating the empty indicator	23

# Table of contents

<b>4</b>	<b>Settings and displays</b> .....	<b>24</b>
4.1	Making settings .....	24
4.2	Language .....	25
4.3	Selecting the empty indicator .....	25
4.4	Setting the signal for the electronic lifting gear control (EHR).....	26
4.5	Adjusting the empty indicator .....	27
4.6	Displaying the spreader type.....	28
4.7	Headland manager (optional accessory).....	28
4.8	Checks .....	30
4.9	Spreading widths and turning procedure.....	31
<b>5</b>	<b>Maintenance and cleaning</b> .....	<b>32</b>
5.1	Maintenance.....	32
5.2	Cleaning .....	35
5.3	Transport and storage .....	35
<b>6</b>	<b>Appendix</b> .....	<b>36</b>
6.1	EC Declaration of Conformity.....	36
6.2	Identification .....	37
6.3	Distribution box layout plan .....	38
6.4	Troubleshooting.....	39
6.5	Spare parts list for the <b>POLARO® E</b> .....	40
6.6	Spare parts list for the control unit.....	42
6.7	Spare parts list for the hopper .....	44
6.8	Spare parts list for the saline agitator.....	46
6.9	Wacker spreading chart .....	48

# 1 What you should know

## 1.1 Foreword

Congratulations on purchasing the **POLARO® E**, a high-quality and innovative product. Thank you for placing your trust in us. Thanks to its advanced design, meticulous material selection, state-of-the-art manufacturing techniques and the precision work of our employees, this equipment meets all efficiency, quality, reliability and value requirements.

Maintaining and servicing according to the operating instructions ensures the safety of the equipment and maintains the value of your **POLARO® E**.



## 1.2 About these operating instructions

These operating instructions are part of the **POLARO® E** and must always be readily available. They must be read, understood and followed by everybody who works with the **POLARO® E**. Keep the operating instructions for future use. If you come to sell your **POLARO® E**, give the buyer these operating instructions; they are an integral part of the equipment.

# 1 What you should know

## Warnings

Warnings in these operating instructions are identified as follows:

	<b>Danger!</b> Warning against immediate danger. Non-observance of appropriate measures may result in death or severe personal injury or serious damage to property.
	<b>Warning!</b> Warning of possible danger. Death, severe personal injury or serious damage to property are possible.
	<b>Caution!</b> Warning of possible dangerous situations. Slight personal injury or damage to property is possible.

## 1.3 Description of the POLARO® E

The POLARO® E is a spreader for spreading winter salt, grit, sand and granulated fertilisers and comprises a solid frame, a spreading material hopper and the electrical components. The frame includes the spreading disc with slider/dosing equipment. The electrical components comprise the drive motor, sensors and magnets, distribution control box, control console cable, control cable, battery cable and control console.

A separate motor drives a slow-running agitator for grit, sand, smooth flowing salt or granulated fertiliser. As an alternative for slow-flowing or damp salt, a special saline agitator is available as an accessory. This agitator is mounted in an upright position in the hopper.

The speed of the spreading plate, the dosing unit and the flow quantity can be regulated from a control panel in the driver's cab.

The POLARO® E can be mounted on the front or rear of approved carrier vehicles.

## Technical data

# 1 What you should know

	POLARO® E 70	POLARO® E 110	POLARO® E 170	POLARO® E 250
Dimensions L/W/H	570/485/870 mm	570/485/1050 mm	700/626/1070 mm	670/800/1100 mm
Unladen weight	29 kg	38 kg	42 kg	53 kg
Capacity	70 l	110 l	170 l	250 l
Volumetric capacity Salt	90 kg	140 kg	220 kg	325 kg
Operating voltage	12 to 15 Volts			
Fuse	25 Ampere			
Power of drive motor (spreading disc)	100 W			
Power of mixer motor	150 W			
Speed range	40 to 600 rpm			
Standard speed of agitator	54 rpm			
Speed of saline agitator	27 - 29 rpm			
Power consumption of motor	Start up to 25 A Normal operation up to 13 A			
Operating temperature	-10°C to +70°C			
Storage temperature	-30 °C to +70°C			
Length of battery cable	3 m	5 m	5 m	5 m
Length of control console cable	2 m	2 m	2 m	2 m
Length of control cable	3 m	6 m	6 m	6 m



# 1 What you should know

## 1.4 Intended use

The **POLARO® E** is a spreader for spreading winter salt, grit, sand and granulated fertilisers.

## 1.5 Reasonably predictable misuse

Only use on approved carrier vehicles with suitable on-board electrical systems and sufficient structural integrity.

Only use for approved media. The equipment must not be used for spreading crop protection products.

## 1.6 Warranty

We offer a 24 month warranty on the **POLARO® E**.

Warranty repairs must be coordinated with the manufacturer before any work is started.

For replacement parts, additional expenses are automatically charged for any changes made to cables and plugs by the customer. Replacement parts are to be returned carriage paid.

Any changes to cable or plug connections without factory approval automatically invalidate the entire warranty. Rusted bearings are not subject to the manufacturer's warranty. Motors may not be opened or dismantled.

On receipt:

Check your **POLARO® E** for transport damage on receipt.

Any such damage must be reported to the manufacturer within 24 hours of receipt.



# 1 What you should know

## 1.7 About your safety

- Carefully read and observe these operating instructions before use. Always keep this manual to hand at the point of use.
- Observe the accident prevention regulations, safety and operating regulations and the regulations for environmental protection.
- Observe all applicable standards and guidelines.
- Observe the safety instructions.
- Before operation, check that the hopper is correctly seated in its mounting and that the spreader is safely and correctly attached to the carrier vehicle.
- Do not operate the spreader if there are technical safety defects.
- Immediately resolve any safety-related defects.
- When travelling on public roads and streets, observe the road traffic regulations.
- There must be no other persons in the spreading zone.
- Switch off the motor before troubleshooting.
- Disconnect the electrical power supply for maintenance work.
- Never open the hopper when the agitator is running.
- Do not reach into the hopper during operation.
- Never reach into the rotating or blocked spreading disk whilst the motor is running.
- Comply with the regulations of the spreading material manufacturer.
- It is essential to comply with the instructions of the spreading material manufacturer in question.
- Spreading tables and additional information about the spreading material used can be requested from the spreading material manufacturer in question.
- LEHNER Agrar GmbH cannot accept any liability for the storage and application of the spreading material.

## 2 Mounting and starting

### 2.1 Installing the frame

	<p><b>Warning!</b> <b>Risk of injury due to high component weight</b></p> <p>The spreader is significantly heavier when the hopper is full. Attention must therefore be paid to the proper mounting of the spreader on the carrier vehicle, and to the carrying capacity of the vehicle tailgate or other panels. If necessary, fit with assistance.</p>
	<p><b>Warning!</b> <b>Risk of injury</b></p> <p>The load carrying capacity shall be based on the regulations for load bearing equipment.</p>
	<p><b>Warning!</b> <b>Risk of injury</b></p> <p>Do not operate the spreader if there are technical safety defects.</p>

The POLARO® E can be mounted on the front or rear of the tractor, off-road vehicle or ATV.

The POLARO® E can be mounted using an auxiliary bracket. Mounting holes are provided on the back of the framework for this purpose.

Remove the hopper before mounting the spreader.

The recommended delivery height is 0.40 - 0.80 m. For further information and the required speed and slide opening for Wacker winter salt, see chapter 6.6 - Wacker spreading chart.

For the values for other spreading products, please refer to the information provided by the spreading material manufacturer.

For information on disassembly, see chapter 5.1 - Maintenance.

## 2 Mounting and starting

### 2.2 Mounting the hopper and deflector plate

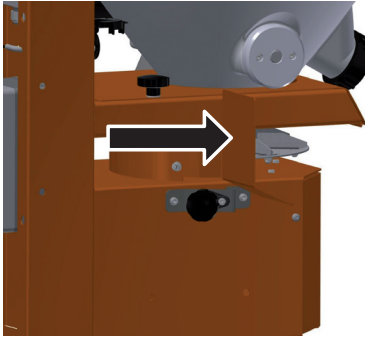

#### **Warning!**

#### **Risk of injury and damage to the spreader**

As an alternative for slow-flowing salt, a refined salt agitator is available as an accessory. This agitator is not suitable for grit or sand.

1. Mount the hopper.
2. Check whether the hopper fits well in the hopper platform at the bottom.
3. Using screws, attach the included deflector plate to the spreader (arrow).
4. Check that the **POLARO® E** is securely attached.

## 2 Mounting and starting

### 2.3 Electrical connection

	<p><b>Caution!</b> <b>Risk of functional failures</b></p> <p>Faulty or incorrectly dimensioned plugs and cables can lead to malfunctions. Only use original plugs and cables, or ones approved by the manufacturer.</p>
---	---

	<p><b>Caution!</b> <b>Danger of short circuit</b></p> <p>Ensure that the cable is not routed over any sharp edges.</p>
---	--

Any changes to cable or plug connections without factory approval automatically invalidate the entire warranty. Changes to cables undertaken by the customer shall be subject to additional charges in the event of repairs.

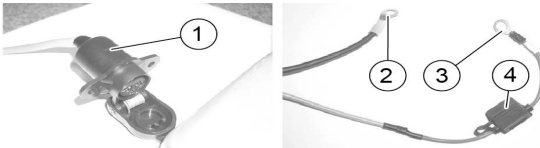

1. Mount the support for the control console in the vehicle cabin.
2. Plug the control console cable into the three-pin socket **1** of the carrier vehicle.

If such a socket **1** is not available, use the battery cable supplied:

- Connect terminal **2** to the negative terminal of the battery (not to the bodywork).
- Connect connector **3** (with fuse **4**) to the positive terminal of the battery
- Route the end of the cable with socket **1** into the carrier vehicle.

## 2 Mounting and starting

3. Plug the spreader cable into the 16-pin socket of the control panel.

**To ensure an optimum electrical power supply, use the supplied battery cable.**

	<p><b>Caution!</b> <b>Danger of short circuit</b> Observe the installation instructions of the adapter manufacturer.</p>
---	--

When fitting a 12/24 V adapter (available as an accessory) it is necessary to connect a separate on/off switch in the 24 V supply cable, as the adapter consumes current in standby mode.

Your equipment is now ready to operate.

### 2.4 Filling the spreading material hopper

	<p><b>Caution!</b> <b>Health risk</b> Comply with the regulations of the spreading material manufacturer.</p>
---	---

	<p><b>Warning!</b> <b>Risk of injury</b> Never open the hopper or touch the spreading disc when the drive motor is running.</p>
--	---

1. Fill the hopper with spreading material immediately before starting work.

2. After filling, close the hopper.

# 3 Operating the POLARO® E

## 3.1 Controls on the control console



- 1 Switching on / off
- 2 Display
- 3 Opening and closing the slide  
Slide open: green LED lights up  
Slide closed: yellow LED lights up
- 4 Setting the speed or slide opening
- 5 Switch to change between speed and slide
- 6 Empty indicator

# 3 Operating the POLARO® E

## 3.2 Indicators in the display

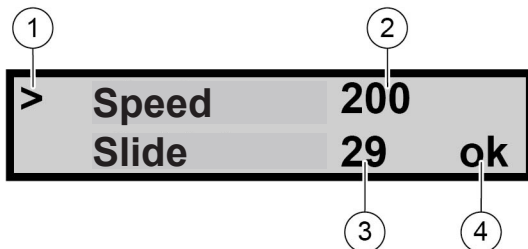

- 1 Arrow denotes the active line
- 2 Spreading disc speed
- 3 Slide opening
- 4 OK sign for open slide





For more information, see chapter 6.4 - Troubleshooting.



# 3 Operating the POLARO® E

## 3.3 Switching the spreading disc and agitator on and off

	<p><b>Danger!</b> <b>Risk of injury by accident</b></p> <p>When travelling on public roads and streets, observe the road traffic regulations.</p>
	<p><b>Warning!</b> <b>Risk of injury</b></p> <p>The drive motor starts immediately when switched on. Make sure that no-one is in the danger area when you switch the system on.</p>
	<p><b>Warning!</b> <b>Risk of injury</b></p> <p>Do not operate the spreader if there are technical safety defects.</p>

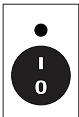

Press the button to switch on the equipment. The speed of the spreading disc and the slide opening is displayed. The slide is always closed when the equipment is switched on; this allows the slide to be calibrated in its 0 position.

> RPM	200
Slide	29

If this message is displayed, a cable is damaged or a plug disconnected.

> RPM	200
Spr. connection	

Low temperatures can cause the empty indicator to respond slowly. To check the adjustment:

Let the spreader run for approx. 1 minute with the slide closed.

If the slide is now opened, the empty indicator must respond after approx. 5 seconds.

If this does not happen, adjust the empty indicator in the negative range by 5%. For more information, see chapter 4.5 - Adjusting the empty indicator.

### 3 Operating the POLARO® E

#### Autostart/automatic freewheeling

If a motor is difficult to start due to heavy loads, start the motor up to 10 times in alternating motor direction. For this, the slider must be open so that the material flows out. If the agitator or spreading disc still cannot break free, the motor is automatically switched off.

The following message is shown in the display:

**Agitator stationary**, if the agitator cannot break free.

**Disc blockage**, if the spreading disc cannot break free.



**Warning!**

**Risk of injury due to unexpected starting of the agitator or spreading disc**

Switch off the motor before troubleshooting.

To eliminate the blockage:

1. Switch off the machine.
2. Manually turn the spreading disc or empty the hopper.

For more information, see chapter 6.4 - Troubleshooting.

# 3 Operating the POLARO® E

## 3.4 Setting the speed



If necessary, press the toggle switch to select the speed; the arrow points to the first line in the display.

> RPM	200
Slide	29

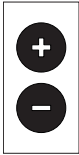

Press the key to set the rotary speed. The speed can be steplessly adjusted from 40 - 600 rpm. In the display, the setpoint speed is shown for ten seconds, and only then followed by the actual speed.

## 3.5 Setting the slide opening



If necessary, press the toggle switch to select the slide. The arrow points to the second line in the display.

Speed	200
> Slide	29

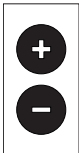

Press the key to set the slide opening.

# 3 Operating the POLARO® E

## 3.6 Opening/closing the slide

	<p><b>Warning!</b> <b>Risk of injury</b></p> <p>The drive motor starts immediately when switched on. Make sure that no-one is in the danger area when you switch the system on.</p>
---	---

	<p>Press the button to open or close the slide. Slide open: green LED lights up. Slide closed: yellow LED lights up.</p>	<table border="1"><tr><td>&gt; RPM</td><td>200</td></tr><tr><td>Slide</td><td>29 OK</td></tr></table>	> RPM	200	Slide	29 OK
> RPM	200					
Slide	29 OK					

### Slide monitoring

If the slide does not reach the specified position within 10 seconds, the spreader switches off.

The following message is shown in the display:

**Slide not open** or **Slide not closed**. 5 warning signals also sound.

	<p><b>Warning!</b> <b>Risk of injury</b></p> <p>Switch off the motor before troubleshooting.</p>
---	--

# 3 Operating the POLARO® E

## Troubleshooting

The following steps must be observed when the error message **Slide not open** or **Slide not closed** appears in the display.

1. Switch off the control console.
2. Wait 15-20 seconds.
3. Switch on the control console.

The slide automatically opens/closes by approx. 10 mm. This allows the foreign body to be removed. If this is not the case, the foreign body must be removed manually.

4. Wait 15-20 seconds.
5. Switch off the control console.
6. Switch on the control console.

The slide closes automatically and the 0 position is reached.

Important note:

Once the blockage has been successfully removed, before refilling the hopper, ensure that the slide is in the 0 position (is fully closed). Check by taking a quick look inside the hopper.

## 3.7 Setting the working width

The spreading width depends on the condition of the spreading material and the speed of the spreading disc. The more coarse the spreading material, the larger the possible spreading width.

1. Set the speed according to the spreading chart.
2. Set the casting blades according to the spreading chart.

# 3 Operating the POLARO® E

## 3.8 Setting the spreading zone

You can set the zone within which the spreading material is to be spread. This allows you to spread the material on a pavement for example when the carrier vehicle is running along the road.

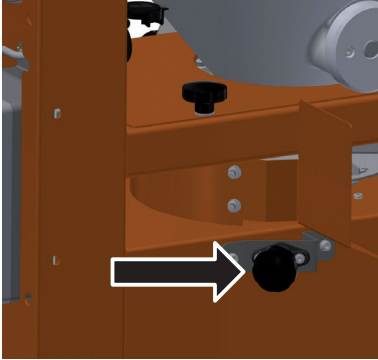

Spread the spreading material in the left-hand direction of travel (when mounted at the rear):  
turn the spindle (arrow) clockwise.

Spread the spreading material in the right-hand direction of travel (when mounted at the rear):  
turn the spindle (arrow) counter-clockwise.

## 3.9 Empty sensor

The empty indicator indicates when the spreading material in the hopper drops below a certain level.  
The following message flashes in the display for approx. 5 seconds: **Hopper empty**. At the same time, eight warning signals also sound and the red LED on the empty sensor flashes.

To switch off the empty sensor again:  
close the slide or switch off the spreader.

# 3 Operating the POLARO® E

## 3.10 Calibrating the empty indicator

	<p><b>Caution!</b> Machine automatically calibrates the empty indicator. Risk of injury!</p>
---	--

	<p><b>Danger!</b> The drive motor starts immediately when switched on. Make sure that no-one is in the danger area when you switch the system on.</p>
---	---



Press and hold the On/Off button for about eight seconds.

Machine starts the calibration automatically. The spreading disc rotates for 30 seconds at maximum rpm. It then falls very slowly to 0 rpm. The parameters are stored in the controller.

Calibration takes three minutes.

During calibration of the empty indicator, the following message appears on the display.

Error FLP = PWR
-----------------

The spreader switches off automatically once calibration is completed.

Calibration of the empty indicator has been successfully completed. It is now possible to spread by restarting the machine.

# 4 Settings and displays

The control element can be used to make the following settings:

Language

Empty indicator selection

EHR signal

EHR cycle

Empty indicator adjustment

Spreader type

Number of spreaders

The EHR cycle and number of spreaders are not needed when working with the POLARO® E.

## 4.1 Making settings

Switch off the machine.

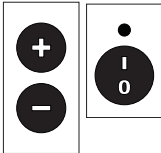

Hold down the + and - key. While doing so, switch on the control panel. **Keep all three keys pressed “together” for about 3 seconds.**

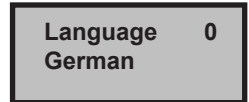

The language selection is displayed.



Press the toggle switch to select the desired menu item.



# 4 Settings and displays

## 4.2 Language

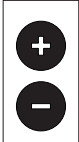

Press the key to set the language.

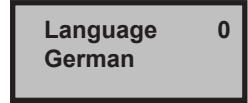

Press the toggle switch: the setting is saved and now press the next menu item or

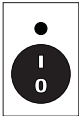

main switch: the setting is saved and the machine switched off.

## 4.3 Selecting the empty indicator

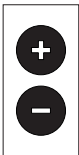

Press the button to select the empty indicator:  
From spreading disc resistance (1),  
via agitator motor (2) with soft agitator,  
via external empty indicator (3) – not  
programmed  
or  
empty indicator switched off (0).

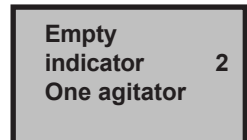

Press the toggle switch: the setting is saved and now press the next menu item or



main switch: the setting is saved and the machine switched off.

# 4 Settings and displays

## 4.4 Setting the signal for the electronic lifting gear control (EHR)

When the spreader is equipped with the headland manager accessory, the hydraulic signal of the tractor can be detected. This signal is emitted when lifting or lowering.

The spreader's factory setting is to output the signal when lifting. If the tractor emits the hydraulic signal when lowering, you can adjust the spreader.

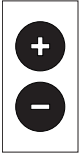

Press the key to set the EHR signal.  
EHR signal for lifting:  
**High active** is displayed.  
EHR signal for lowering:  
**Low active** is displayed.

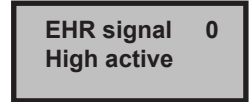

Press the toggle switch: the setting is saved and now press the next menu item or

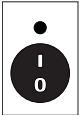

Main switch: the setting is saved and the machine switched off.

# 4 Settings and displays

## 4.5 Adjusting the empty indicator

Depending on the requirement and spreading material, the empty indicator can be set to respond earlier or later.

The value for the empty indicator to switch on (if the spreading material falls below a certain fill level) can be adjusted from -50 to +50.

**Note:**

Depending on the spreading material or material humidity, the remainder level may vary somewhat.

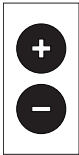

Press the button to set the respective value.

Factory setting is 0.

With + values, the empty indicator responds at a higher fill level.

**With - values, the empty indicator responds at a lower fill level.**

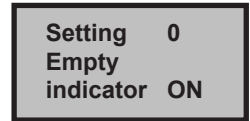

Press the toggle switch: the setting is saved and now press the next menu item or

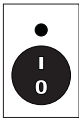

Main switch: the setting is saved and the machine switched off.

# 4 Settings and displays

## 4.6 Displaying the spreader type

The control is provided for a variety of spreaders. The POLARO® B (Bosch motor) is programmed at the factory.



Press the toggle switch: the setting is saved, press the next menu item or main switch: the setting is saved and the machine switched off.

Spreader type 2
POLARO B

## 4.7 Headland manager (optional accessory)

If the headland manager is connected, a \* is displayed at the end of the first line.

Speed	200*
Slide	29

With the headland manager, the slide is automatically opened when the hydraulics are lowered and automatically closed when lifting. The slide can be stopped and closed **manually at any time** using the control panel.

The signal can be detected by means of a 7-pin plug or a sensor signal.

### 7-pin socket



1. Connect the control console cable to the 7-pin signal socket of the carrier vehicle.
2. Set the EHR signal of the carrier vehicle depending on whether the tractor emits the hydraulic signal when lifting or lowering.

# 4 Settings and displays

## Sensor signal

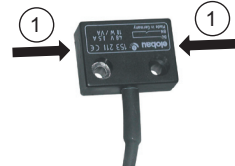
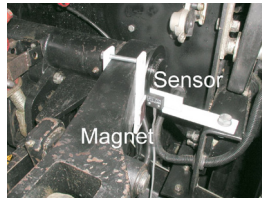

1. Secure the sensor in the joint area of the lower link.
2. Secure the magnetic encoder to the lower link.
3. Set the position of the sensor and the magnetic encoder.

Maximum distance 10 mm.

- Hydraulics lowered:  
Sensor not in field of magnetic encoder.  
Hydraulics at the height where the slide should close or open:  
Sensor just reaches field of magnetic encoder.
- Hydraulics lifted:  
Sensor must still be in field of magnetic encoder. When the hydraulics are lifted, the sensor must not leave the field of the magnetic encoder, as otherwise the slide will open again.

Please note that the contact surfaces 1 of the sensor are only located on the left and right sides.

# 4 Settings and displays

## 4.8 Checks

### Voltage check

To check the operating voltage (in Volts), the spreader must be on.



Press the button for 5 seconds.  
The operating voltage is displayed for 8 seconds.  
**Factory recommendation min. 12.6 V.**



### Performance check

The motor is set at the factory. No changes are permitted, since otherwise the drive and control parameters no longer match.

To check the performance data, the spreader must be on.



Press the button for min. 5 seconds.  
The following information is displayed as long as the button is pressed:  
**Line 1:** current drive motor, power consumption in Watts and the exact speed.  
**Line 2:** R value for factory-internal data, the motor voltage in Volts, the current consumption of the motor in Ampere.

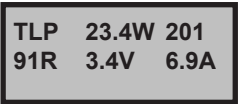

# 4 Settings and displays

## 4.9 Spreading widths and turning procedure

The reference values for the spreading width are provided in the information supplied by the relevant spreading material supplier.

### Turning down

1. Put the spreader in the carton or put the carton over the spreader to catch the spreading material.
2. Due to the suction effect, the speed of the spreading disc used in practice must be set.
3. Weigh the ejected spreading material at various slide positions until the suitable slide position is determined.

### Determining the spreading width

1. Spread on a firm surface.
2. Weigh spreading material or sweep up a swath lateral to the direction of travel and assess the lateral distribution.

### Formulae



$$\frac{\text{Gram/min}}{\text{Speed in m/min} \times \text{Spreading width in m}} = \text{Output rate in gram/m}^2$$

$$\frac{\text{Gram/min}}{\text{Output rate in gram/m}^2 \times \text{spreading width in m}} = \text{Speed in m/min}$$

$$\text{Desired output rate in gram/m}^2 \times \text{speed in m/min} \times \text{spreading width in m} = \text{gram/min}$$

# 5 Maintenance and cleaning

## 5.1 Maintenance

	<p><b>Warning!</b> <b>Risk of injury</b> Disconnect the electrical power supply for maintenance work.</p>
	<p><b>Warning!</b> <b>Risk of injury due to high component weight</b> If necessary, remove with assistance.</p>
	<p><b>Warning!</b> <b>Risk of injury</b> Always wear goggles, dust mask and gloves when cleaning. Comply with the regulations of the spreading material manufacturer.</p>

After use, empty the material hopper and clean the spreader and carrier vehicle with compressed air.

### Dosing device/slide

The dosing device and slide should be inspected and cleaned at regular intervals depending on use and the spreading material used. If using very fine spreading material in particular, the slide unit may clog.



## 5 Maintenance and cleaning

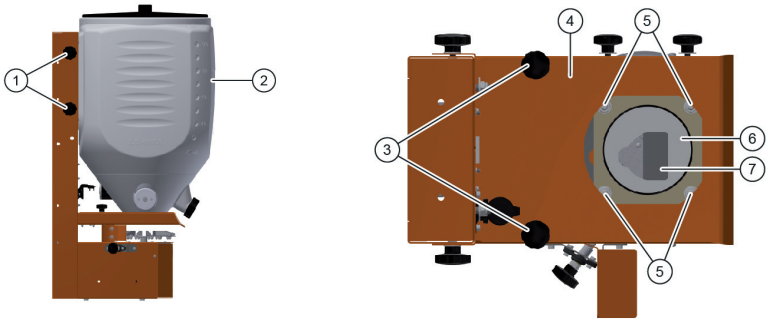

1. Disconnect agitator plug.
2. Unscrew upper and lower knurled screws **1** on both sides.
3. Remove the hopper **2**.
4. Unscrew knurled screws **3** and take off cover plate **4**.
5. Unscrew the nuts **5** using a 17 mm spanner.
6. Remove hopper platform **6** and pull dosage slider **7** out from the top.
7. Clean the slide unit with a brush or compressed air.
8. Fit parts in reverse order.  
Standard lubricant can be applied to the bottom edge to assist with hopper installation.

# 5 Maintenance and cleaning

## Drive motor

The drive motor of the spreading disc should be cleaned and greased at the end of the season. This extends the service life of the motor. Carry out the maintenance work correctly, otherwise the manufacturer's warranty may be invalidated.

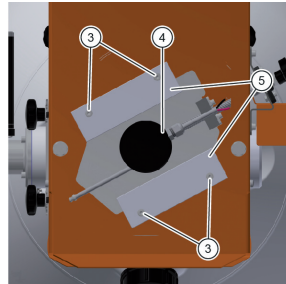
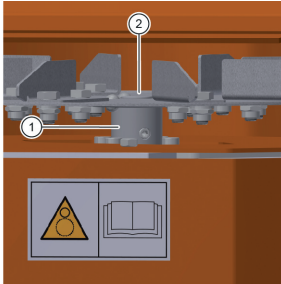

1. Disconnect agitator plug.
2. Loosen screw 1 on spreading disc 2 and pull spreading disc 2 up and off.
3. Remove plastic washer.
4. Remove screws 3 from below and remove drive motor 4 with spacer and two guide rails 5.
5. Take spacer ring with shaft seal off the motor shaft.
6. Clean motor shaft and contact surface of plastic washer and apply thin coat of standard copper paste.
7. Fit parts in reverse order.

During the season, the drive motor and the agitator motor must be lubricated. A grease nipple for each is located on the front plate (drive motor) and hopper (agitator motor).

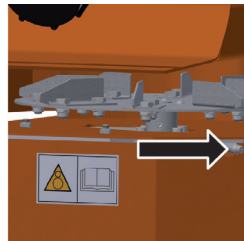
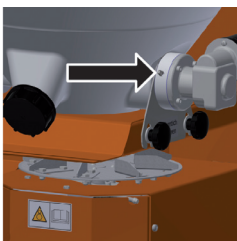

# 5 Maintenance and cleaning

## 5.2 Cleaning

	<p><b>Warning!</b> <b>Risk of injury</b> Disconnect electrical power supply for cleaning work.</p>
---	--

	<p><b>Caution!</b> <b>Risk of injury</b> Always wear goggles, dust mask and gloves when cleaning. Comply with the regulations of the spreading material manufacturer.</p>
---	---

The hopper can be almost fully emptied by means of the residual discharge.

1. Unscrew hopper.
2. Clean spreader and hopper with a brush.

## 5.3 Transport and storage

For transportation, only the trolley available as a special accessory should be used.

	<p><b>Warning!</b> <b>Risk of injury from parked equipment falling over</b> Park the equipment on a clean, dry surface with an adequate load capacity. For extended periods, the equipment may only be stored completely empty.</p>
---	---

# 6 Appendix

## 6.1 EC Declaration of Conformity

### EC Declaration of Conformity

in accordance with the EC Machinery Directive 2006/42/EC, Appendix II, 1.A

**Manufacturer:**

LEHNER Agrar GmbH  
Häuslesäcker 5-9  
89198 Westerstetten

**Person resident in the Community who is entitled to assemble the relevant technical documents:**

Helmut Lehner  
LEHNER Agrar GmbH  
Häuslesäcker 5-9  
89198 Westerstetten

**Description and identification of the machine:**

Product: POLARO® E  
Type: 70/110/170/250

Function: The POLARO® is a spreader for spreading winter salt, grit, sand and fertilisers or various types of granulated products. It is produced in three sizes. These differ in the hopper capacity: 70, 110, 170 and 250 litres. A separate motor drives a slow-running agitator, which can be installed horizontally or vertically. The agitator keeps the spreading material free-flowing. The speed of the spreading disc and the degree of opening of the slide are steplessly controlled via a control console in the driver's cab.

**It is expressly declared that the machine is in accordance with all relevant provisions of the following EC Directives:**

2006/42/EC:2006-05-17	EC Machinery Directive 2006/42/EC
2004/108/EC	(Electromagnetic Compatibility) Directive 2004/108/EC of the European Parliament and of the Council of 15 December 2004 on the approximation of the laws of the Member States relating to electromagnetic compatibility and repealing Directive 9/336/EEC

**Source of the applied harmonised standard acc. to Article 7, para. 2:**

EN ISO 12100-2:2003-11	Safety of Machinery – Basic concepts; general principles for design – Part 2 Technical principles
EN ISO 14121-1:2007	Safety of Machinery – Risk assessment – Part 1: Principles (ISO14121-1:2007)
EN 50498:2010	Electromagnetic compatibility (EMC). Product family standard for aftermarket electronic equipment in vehicles.
EN ISO 14982:2009	Electromagnetic compatibility – Agricultural and forestry machinery

**Source of the applied other technical standards and specifications:**

EN ISO 12100-1:2003-11	Safety of Machinery – Basic concepts; general principles for design – Part 1: Basic terminology, methodology
------------------------	--

Westerstetten, 29.08.2011  
Place, date



Signature  
Helmut Lehner



# 6 Appendix

## 6.3 Distribution box layout plan

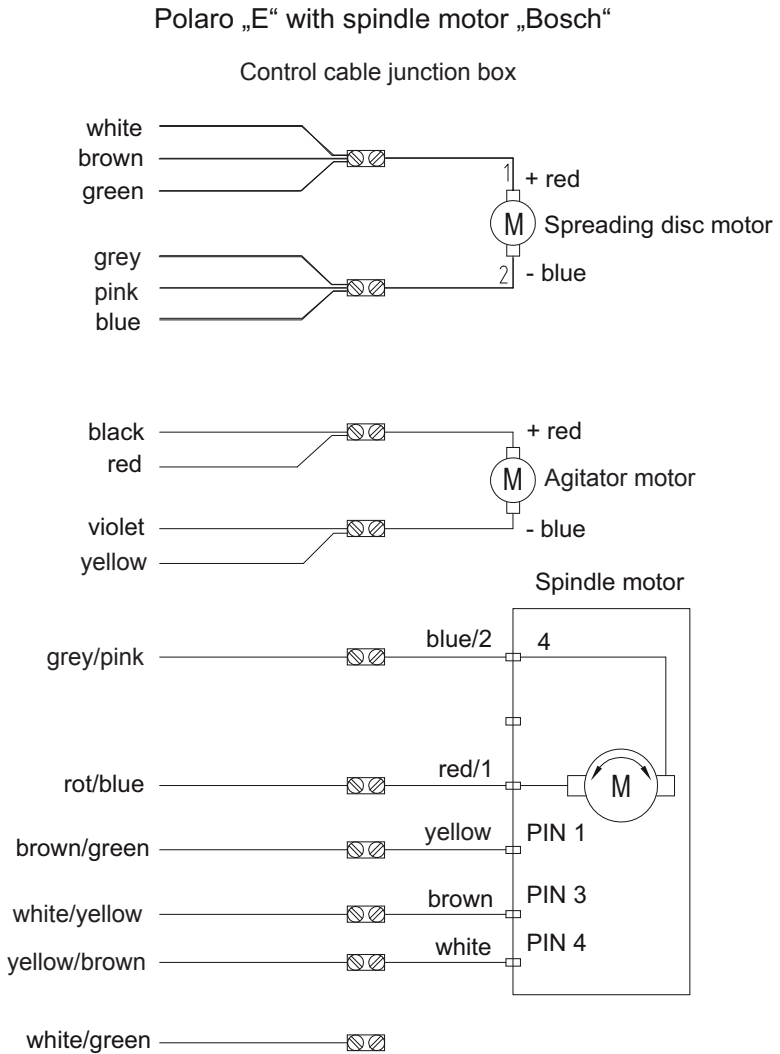

# 6 Appendix

## 6.4 Troubleshooting

<b>Troubleshooting the LEHNER POLARO® E</b>	
The following information should help you resolve minor problems yourself. You are welcome to call us as needed. We are glad to help.	
<b>Problem</b>	<b>Cause</b>
<b>Solution</b>	
Cracking in the control console	Loose contact on the power supply
No display	+ and - were switched, fuse is defective
Spreading disc does not reach set speed	Excess load, motor bearing not running smoothly
Slide jams	Spreading material or dirt has got jammed in the slide
On the display: Disc blockade	Spreading disc does not turn; switched off after 10 attempts
On the display: Agitator stationary	Agitator not rotating; has switched off after ten attempts; material may be too heavily compacted
	Agitator motor cable not plugged in
On the display: Slide not open	Slide could not go into position when opening
On the display: Slide not closed	Slide could not go into position when closing
On the display: Agitator blocked	Agitator motor has excess power consumption
The version is displayed again and again	Fuse oxidised, loose contact
Slide does not open; no error message in display	Mechanical damage to slide mechanics
On the display: Spr. connection	Control console plug not connected to spreader or cable damaged
	Power supply below 12 V
	Component failure in control console
Empty indicator does not respond	Empty indicator is set too low
Headland manager closes the slide when lowering hydraulics and opens when lifting	Signal incorrectly applied
Headline manager does not always close	Distance between sensor and magnetic encoder too great
	Check contacts and fuses
	Check connections and fuses
	Check motor for ease of movement
	Check slide for foreign bodies and clean
	Check spreading disc; possibly restart spreader
	Check agitator; possibly restart agitator
	Plug in agitator motor cable
	Rectify fault; see chapter 3.6 - Opening/closing the slide
	Rectify fault; see chapter 3.6 - Opening/closing the slide
	Empty hopper
	Check contacts and fuses
	Check slide motor and mechanics
	Check plug connections and lines
	Restart machine
	Check power supply
	Replace control console
	Adjust empty indicator; see chapter 4.5 - Adjusting the empty indicator
	Change signal; see chapter 4.4 - Setting the signal for the electronic lifting gear control (EHR)
	Check distance, max. 10 mm.

# 6 Appendix

## 6.5 Spare parts list for the POLARO® E

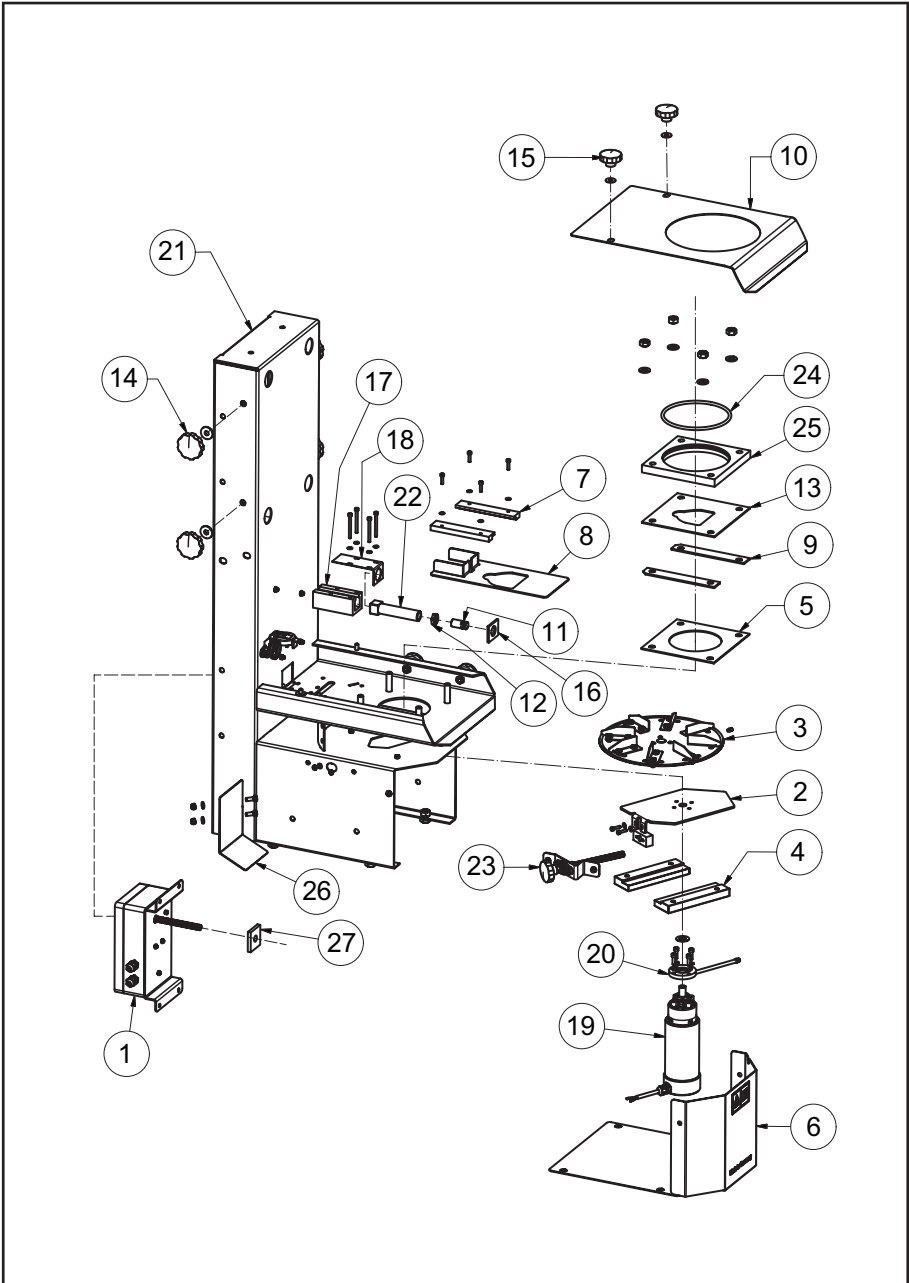



# 6 Appendix

Object	Number	Article No.	Name
1	1	82354	POLARO E motor box, fully mounted
2	1	82087	Strike point adjustment motor retaining plate
3	1	81361	Spreading disc POLARO E
4	2	80541	Guide rails POM POLARO E disc drive
5	1	80496	Base plate POLARO E from POM
6	1	81406	Front and bottom plate POLARO E
7	2	80542	Guide rails POM POLARO E slide
8	1	82085	Dosing slide POLARO E
9	2	82086	Slide guide POLARO E
10	1	81619	Cover plate POLARO E
11	1	81136	Slide adjustment
12	1	81153	Lock nut M14x1 SW19
13	1	81750	Dosage plate POLARO E 2 mm
14	4	73214	Star grip screws 50 mm M8x14 mm V2A
15	2	73216	Star grip nuts 40 mm M6 A2
16	1	81711	Felt gasket linear slide
17	1	81751	Linear slide guide POM
18	1	81712	Linear slide guide cover
19	1	80141	Drive motor POLARO
20	1	82052	Distance ring with shaft seal
21	1	80560	Base frame POLARO E 110, 170
22	1	81740	Linear slide, steep thread nut 10x50
23	1	73404	Strike point adjustment spindle unit
24	1	81395	Hopper seal
25	1	80264	Hopper platform with straight groove
26	1	80679	Impact plate POLARO E 110/ 170
27	1	81940	Combi-tape PTW 150k premium cut

# 6 Appendix

## 6.6 Spare parts list for the control unit

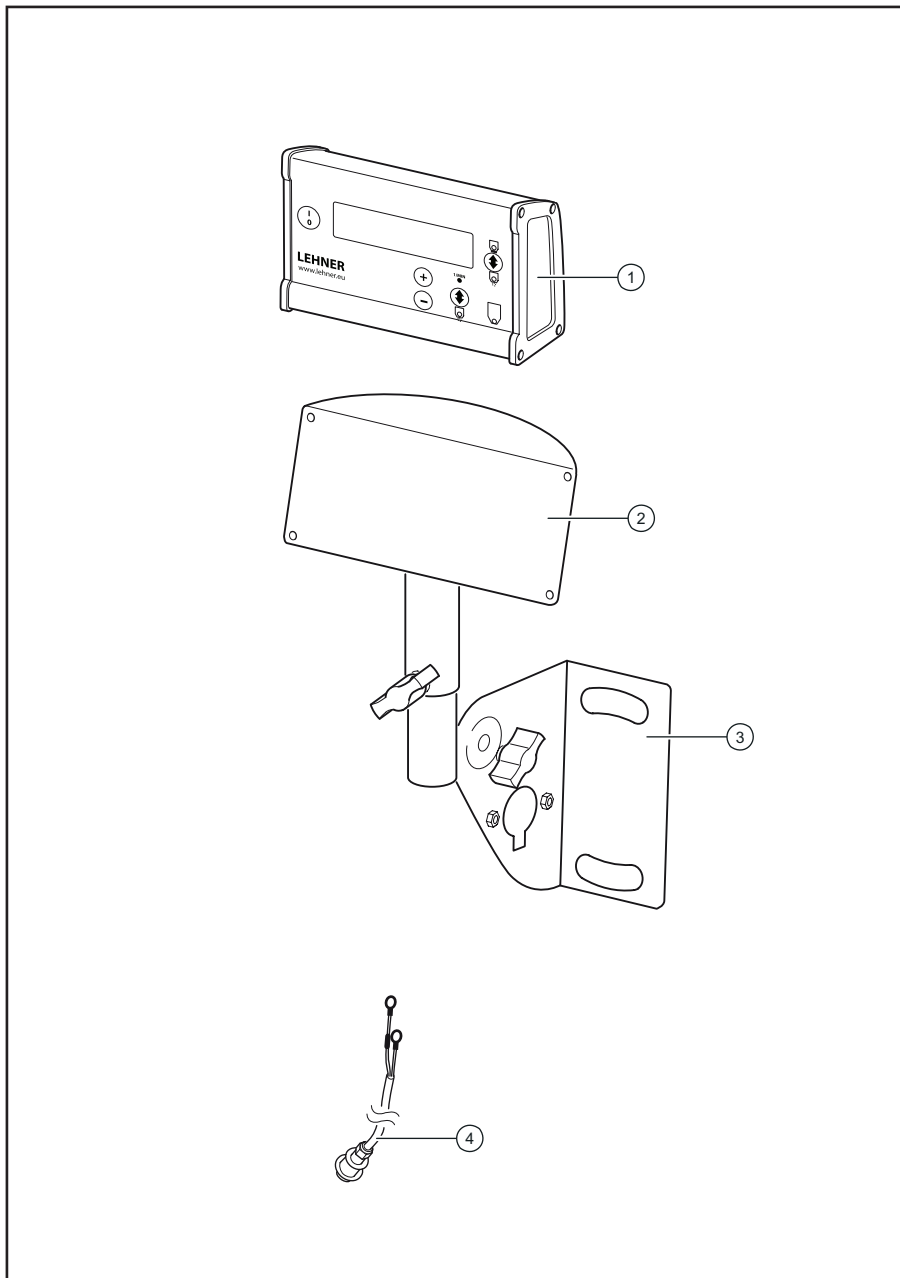

## 6 Appendix

Object	Number	Article No.	Name
1	1	82375	LAS 4 control panel
2	1	80642	Bracket, top part, pivot-mounted
3	1	80643	Bracket, bottom part, pivot-mounted
4	1	80492	Battery cable 2x 4 mm <sup>2</sup> 5 m

# 6 Appendix

## 6.7 Spare parts list for the hopper

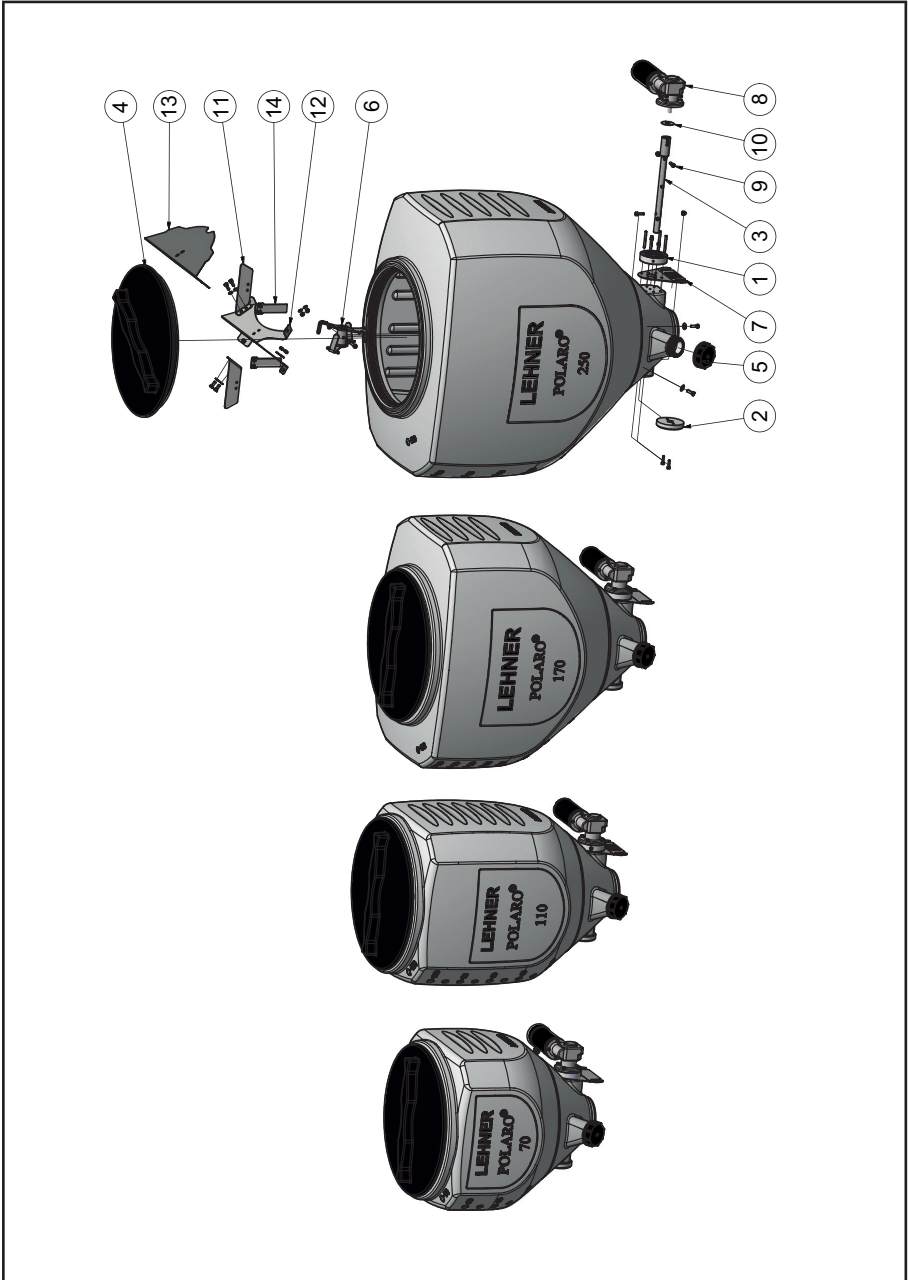

## 6 Appendix

Object	Number	Article No.	Name
1	1	81125	Motor support, agitator with grease nipple
2	1	81126	Agitator shaft bearing POLARO
3	1	81165	Agitator shaft POLARO
4	1	80107	Cover for hopper, black
5	1	80393	Cover for residual discharge, black
6	1	81892	Agitator, stainless steel
7	1	81127	Hopper support for agitator POLARO
8	1	80142	Agitator motor POLARO
9	2	80168	M6 cap nut with M6x25 screw
10	1	82057	Washers 12.2 x 37.0 x 1
11	2	81185	Spring holder for relief roof
12	1	81164	Relief roof POLARO
13	1	82244	Additional relief roof (for grit)
14	2	81186	Spring steel for relief roof

# 6 Appendix

## 6.8 Spare parts list for the saline agitator

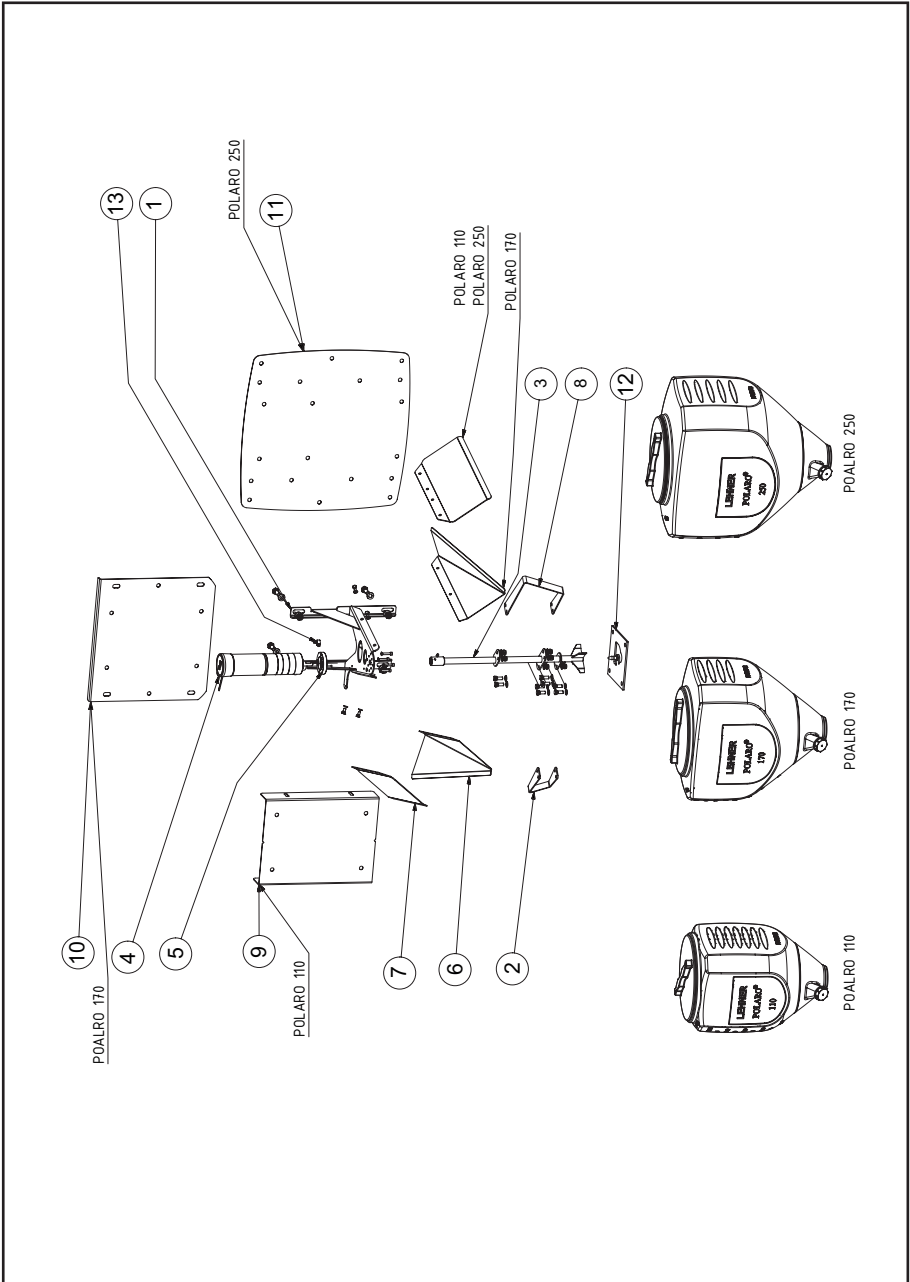

## 6 Appendix

Object	Number	Article No.	Name
1	1	81174	Motor platform for saline agitator
2	1	81189	Stirrer blade 110-170-250 small
3	1	81191	Agitator rod for saline agitator without bracket
4	1	80476	Agitator motor for saline agitator
5	1	80453	Motor cover, saline + screw conveyor
6	1	81328	Relief roof POLARO 170 saline agitator, left and right
7	2	81561	Relief roof POLARO 110 and 250 saline agitator
8	1	81188	Stirrer blade 110-170 large
9	1	81249	Hopper bracket POLARO 110
10	1	80677	Fixing plate POLARO 170 for saline agitator
11	1	82170	Fixing plate POLARO 250 for saline agitator
12	1	81017	Dosage plate, saline agitator E with mandrel
13	1	80612	Conical grease nipple M6, 45° angle

# 6 Appendix

## 6.9 Wacker spreading chart

<b>Spreading chart: <u>Wacker winter salt</u></b>		<b>LEHNER POLARO® E</b>																													
		Delivery height (m): <b>0,60</b>		Last upc <b>02/2008</b>		Check set values in a real-life test.																									
Spreading width (m)		0,8		1,0		1,2		1,5		2,0																					
Speed (rpm)		60		80		100		150		180																					
km/h		5	10	15	20	25	30	5	10	15	20	25	30	5	10	15	20	25	30												
<b>Slide opening:</b>		23	26	29	30	31	32	24	28	30	31	32	33	25	29	31	32	33	26	30	32	33	35	36	28	31	33	35	37	38	
15 g/m <sup>2</sup>		25	29	30	31	33	35	26	30	31	33	35	36	27	31	33	35	36	37	28	32	34	36	37	38	30	33	36	38	40	41
20 g/m <sup>2</sup>		26	30	31	34	36	37	28	31	33	36	37	38	29	32	35	37	38	40	30	33	36	38	40	41	31	35	38	40	42	43
25 g/m <sup>2</sup>		28	31	33	35	37	38	29	32	35	37	38	40	30	33	36	38	40	41	31	35	37	40	41	42	32	37	40	42	43	44
30 g/m <sup>2</sup>		29	32	35	37	38	40	30	33	36	38	40	41	31	35	37	39	41	42	32	36	39	41	42	43	33	38	41	43	44	48
40 g/m <sup>2</sup>		30	34	37	38	40	41	31	36	38	40	42	42	32	37	40	42	43	44	33	38	41	43	44	48	35	40	42	45	49	54
60 g/m <sup>2</sup>		32	36	39	41	42	43	33	38	41	42	44	48	35	40	42	43	48	50	36	41	43	48	54	56	38	42	48	52	58	62
<b>Casting blade setting</b>		central		central		central		central		central		central		central		central		central		central		central		central		central		central		central	
<b>Spreading width (m)</b>		2,5		3,0		4,0		5,0		6,0																					
Speed (rpm)		200		250		350		400		600																					
km/h		5	10	15	20	25	30	5	10	15	20	25	30	5	10	15	20	25	30	5	10	15	20	25	30						
<b>Slide opening:</b>		29	32	35	37	38	40	30	33	36	38	40	41	31	35	38	41	42	43	32	37	40	42	43	44	33	38	41	43	44	48
15 g/m <sup>2</sup>		31	35	38	40	42	43	32	36	39	41	43	44	33	38	41	42	44	48	35	40	42	43	47	51	36	41	43	46	53	54
20 g/m <sup>2</sup>		32	37	40	42	43	44	33	38	41	43	45	47	35	40	42	44	50	53	37	42	44	49	53	55	38	43	48	53	57	60
25 g/m <sup>2</sup>		34	38	42	43	45	46	35	40	43	44	47	53	37	42	44	49	54	57	38	43	48	53	57	61	40	44	53	57	62	67
30 g/m <sup>2</sup>		35	40	43	44	48	50	36	41	44	48	50	54	38	43	48	53	57	61	40	44	53	57	62	70	41	48	54	61	67	
40 g/m <sup>2</sup>		37	42	44	49	53	55	38	43	48	53	57	61	40	45	53	58	64	67	42	49	57	63		43	53	61	67			
60 g/m <sup>2</sup>		40	44	50	57	62	67	41	48	54	61	67	70	43	53	61	67			44	57	66			48	61					
<b>Casting blade setting</b>		central		central		central		central		central		central		central		central		central		central		central		central		central		central		central	

This spreading chart is a reference. Please check your set values.

©LEHNER