

LEHNER

POLARO® L/XL



The 12 V spreader for spreading de-icing salt, sand and fertiliser.

- Infinitely variable control of the spreading width from approx. 0.8 – 6.0 m
- Infinitely variable spreading material application rate
- Operation by control panel from cab/driver's seat
- Hopper capacity of 380l (L) or 550l (XL)

Technical data:	POLARO® L	POLARO® XL
Hopper capacity:	380 l	550 l
Loaded capacity:	approx. 500 kg salt	approx. 720 kg salt
At 20g/m ² :	25 000 m ²	36 000 m ²
Unladen weight:	140 kg	155 kg
Power consumption:	14 A	16 A
Control cable:	5 m	5 m
Fuse:	30 A	30 A
Max. output per minute	approx. 55 kg salt	approx. 55 kg salt



The elasticated tarpaulin is supplied as standard.



Installation on Nissan Navara pick-up



If bridging occurs a vibration unit starts up automatically and stops automatically once the bridging has stopped.

The delivery point on the spreading disc can be changed manually. This changes the side distribution of the material. 8 adjustable casting shovels are attached to the spreading disc too.
Height-adjustable spreading disc.

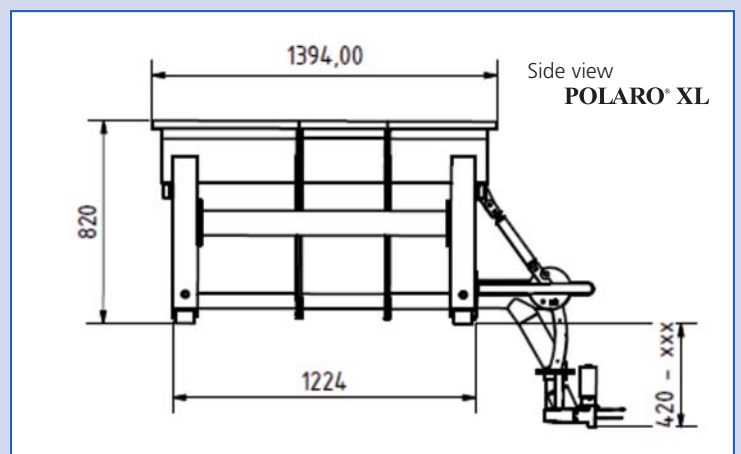
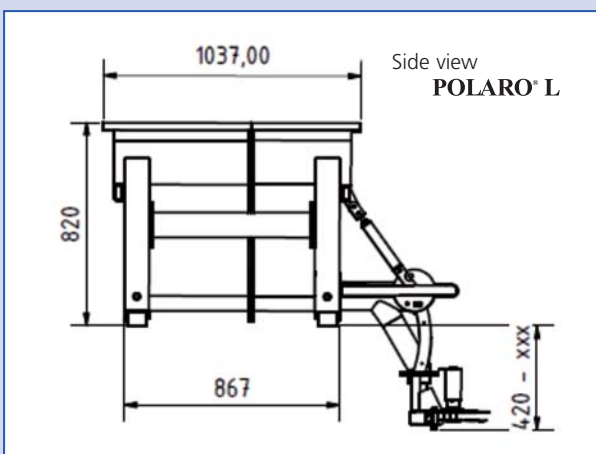
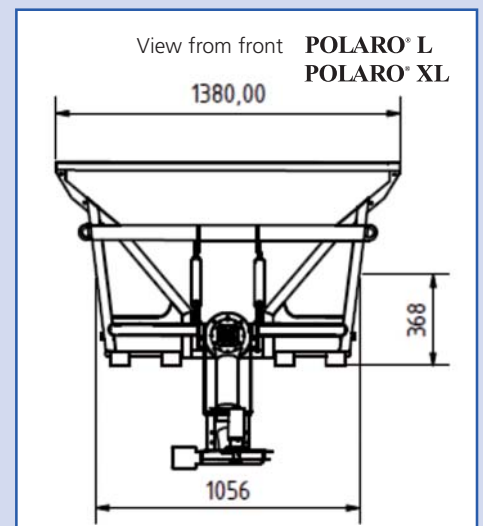

Subject to technical modifications.

LEHNER GmbH
Häuslesäcker 5 - 9
D-89198 Westerstetten

Tel.: (+49) 07348/95960
Fax: (+49) 07348/959640

<http://www.lehner.eu>
E-mail: info@lehner.eu