

LEHNER



MiniVario[®] E

Operating instructions with parts list

Control LAS 3
Software from version 2.1
Status: June 2009

Serial number:

Software version:

Lehner Agrar GmbH

Häuslesäcker 5-9

D-89198 Westerstetten

Tel.: (+49) 07348 95 96 0

Fax: (+49) 07348 95 96 40

www.lehner.eu

info@lehner.eu

Table of contents

1	What you should know	4
1.1	Foreword	4
1.2	About these operating instructions	4
1.3	Intended use	5
1.4	Warranty	5
1.5	About your safety	6
2	Starting up the MiniVario®	7
2.1	Mounting the frame	7
2.2	Electrical connection	7
2.3	Mounting the MiniVario®	8
2.4	Mounting the control panel	9
3	Operating the MiniVario®	10
3.1	Controls on the control panel	10
3.2	The display	11
3.3	Switching on / off	12
3.4	Setting the speed	13
3.5	Setting the slide opening	14
3.6	Opening/closing the slide	14
3.7	Performing the slide reference run	15
3.8	Setting the spreading width	15
3.9	Setting spreading zone	16
3.10	Empty indicator	16

Table of contents

4	Settings and displays	17
4.1	Undertaking settings.....	17
4.2	Language	17
4.3	Selecting the empty indicator	18
4.4	Setting signal for electronic lifting gear control (EHR).....	18
4.5	Adjusting the empty indicator	19
4.6	Displaying the spreader type.....	20
4.7	Headland manager (optional accessory).....	20
4.8	Controls	22
4.9	Spreading width and turning procedure	23
5	Maintenance and cleaning	24
5.1	Maintenance.....	24
5.2	Cleaning	25
6	Appendix	26
6.1	EC declaration of conformity	26
6.2	Identification	27
6.3	Distribution box reference list	28
6.4	Troubleshooting.....	29
6.5	Parts list.....	30
6.6	Spreading charts	34

1 What you should know

1.1 Foreword

Thank you for placing your trust in us. We congratulate you on your decision. With the **MiniVario®**, you have acquired a high-quality and innovative product.

Thanks to its advanced design, meticulous material selection, state-of-the-art manufacturing techniques and the precision work of our employees, this device meets all efficiency, quality, reliability and value requirements.

Maintaining and servicing in accordance with the operating instructions ensures the safety of the device and maintains the value of your **MiniVario®**.



1.2 About these operating instructions

These operating instructions are part of the **MiniVario®** and must always be readily available. All persons who work with the **MiniVario®** must read and follow the operating instructions.

You must become acquainted with the intricacies of the device, have command of the device and optimise its operation.

Warning notices

Warning notices in these operating instructions are identified as follows:

	Danger! Warning of immediate danger. Non-observance of appropriate measures may result in death and severe personal injury or serious damage to property.
	Warning! Warning of possible danger. Death, severe personal injury or serious damage to property is possible.
	Caution! Warning of possible dangerous situations. Slight personal injury or damage to property is possible.

1 What you should know

1.3 Intended use

The **MiniVario**[®] is used exclusively for spreading fertiliser, catch crops, grass, granulates, salt and seed.

1.4 Warranty

We provide a guarantee of 6 months and warranty of 24 months on the **MiniVario**[®].

	<p>Caution! Defective plugs and cables or those of the wrong size can lead to functional deficiencies. Use original or cables and plugs approved by the manufacturer only.</p>
---	---

Any changes to cable or plug connections without factory approval automatically invalidate the warranty. Motors may not be opened or dismantled.

Warranty repairs must be coordinated with the manufacturer before any work is started.

For replacement parts, additional expenses are automatically charged for any changes made to cables and plugs by the customer. Replacement parts are to be returned carriage paid.

Rusted bearings are not subject to the manufacturer's warranty.

Upon receipt:

Check your **MiniVario**[®] for any damage caused in transit. Such damage(s) must be reported to the manufacturer within 24 hours of receipt.

1 What you should know

1.5 About your safety

- Carefully read and observe these operating instructions before use. Always keep these instructions to hand at the point of use.
- Observe the accident prevention regulations, safety and operating regulations and the regulations for environmental protection.
- Observe all applicable standards and guidelines.
- When travelling on public roads and streets, follow the legal rules of the road.
- Observe the safety instructions.
- Do not start up the **MiniVario®** if it has any safety-related deficiencies. Immediately resolve any safety-related deficiencies.
- It is forbidden to stay in the spreading zone. Make sure that nobody is in the spreading zone.
- Do not touch the hopper during operation.
- Do not undertake any repairs, maintenance or cleaning procedures on the **MiniVario®** when the mains plug is connected.

2 Starting up the MiniVario®

2.1 Mounting the frame

The **MiniVario®** can be screwed on directly or an auxiliary bracket used. Mounting holes are provided on the back of the framework.

The recommended delivery height is approx. 0.60 m.

The **MiniVario®** can be attached at the front or rear both on the tractor or ATV or directly to the soil cultivation equipment.

Because the **MiniVario®** is considerably heavier when the hopper is full, the load capacity of the consoles used for attachment should be checked.

2.2 Electrical connection

Technical data

Operating voltage	12 to 15 volts
Fuse	25 A
Power of drive motor (spreading disc)	100 watts
Power of mixer motor	150 watts
Speed range	40 to 600 rpm
Power consumption of motor	Start up to 25 A, normal operation up to 13 A
Operating temperature	-10 to +70 °C
Storage temperature	-30 to +70 °C

Any changes to cable or plug connections without factory approval automatically invalidate the entire warranty. Changes to cables undertaken by the customer are taken into account in the case of repairs.

2 Starting up the MiniVario®

2.3 Mounting the MiniVario®

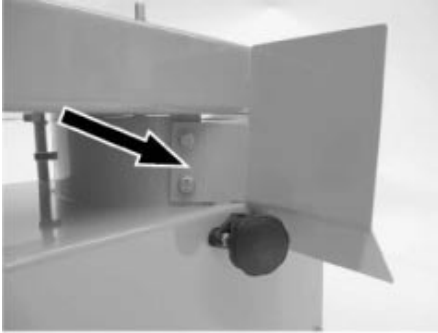

1. Check whether the hopper fits well in the hopper platform.
2. Using screws, attach the included deflector plate (arrow) to the spreader.
3. Check that the **MiniVario®** is securely attached.

2 Starting up the MiniVario®

2.4 Mounting the control panel



Caution, risk of short circuits!

Ensure that the cable is not routed over any sharp edges.

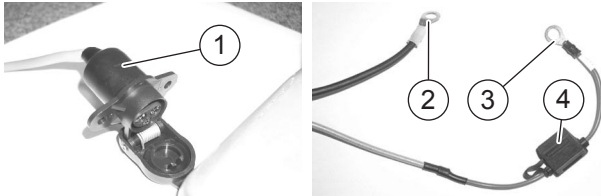

1. Mount support for the control panel in the vehicle cabin.
2. Plug the control panel cable into the 3-pin plug **1** of the carrier vehicle.
If the plug is not available, use the provided battery cable:
Connect terminal **2** to -pin of the battery
(not to the body).
Connect terminal **3** (with fuse **4**) to +pin of the battery
Place cable end with socket in carrier vehicle.
3. Plug the spreader cable into the 16-pin plug of the control panel.
The battery cable supplied must be used to ensure an optimum power supply.

Your device is now ready to operate.

3 Operating the MiniVario®

3.1 Controls on the control panel

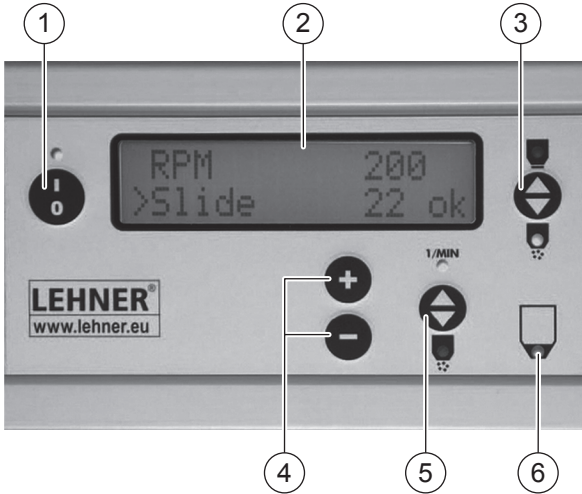

- 1 Switching on / off
- 2 Display
- 3 Opening and closing the slide
Slide open: green LED lights up
Slide closed: yellow LED lights up
- 4 Setting the speed or slide opening
- 5 Switch to change between speed and slide
- 6 Empty indicator

3 Operating the MiniVario®

3.2 The display

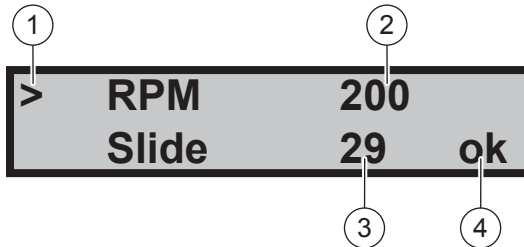

- 1 Arrow denotes the active line
- 2 Spreading disc speed
- 3 Slide opening
- 4 OK sign for open slide



Error messages, also see Troubleshooting chapter.

3 Operating the MiniVario®

3.3 Switching on / off

	Risk of injury! The drive motor starts immediately when switched on. Make sure the danger area is clear when starting.
---	---



Press the button.
The speed of the spreading disc and the slide opening is displayed. The slide is always closed when switching on the drive motor.

> Speed	200
Slide	29

If this message is displayed, a cable is damaged or a plug disconnected.

> Speed	200
Connecting spr.	

Low temperatures can cause the empty indicator to respond slowly. To check the adjustment: Allow the spreader to run for approx. 1 minute with the slide closed. If the slide is then opened, the empty indicator must be activated after approx. 5 seconds. If this doesn't happen, move the empty indicator 5% into the negative range; see Settings and displays chapter, Adjusting the empty indicator.

Autostart/automatic freewheeling

If a motor is difficult to start due to heavy loads, start the motor up to 10 times in alternating motor directions. If the mixer or spreading plate cannot break free as a result, the motor is automatically switched off. The following message is displayed:
Mixer stationary, if the mixer cannot break free.
Disc blocking, if the spreading plate cannot break free.

3 Operating the MiniVario®

	<p>Risk of injury!</p> <p>Never open the hopper or touch the spreading disc when the drive motor is running.</p> <p>Switch off the drive motor and ensure that the motor is stopped before opening the hopper or touching the spreading disc.</p>
---	--

To eliminate the blockage:

1. Switch off the machine.
2. Manually turn the spreading disc or empty the hopper.

3.4 Setting the speed



If necessary, press the toggle switch to select the speed; the arrow points to the first line in the display.

> Speed	200
Slide	29

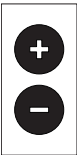

Press the button to set the speed.
The speed can be adjusted continuously from 40 - 600 rpm.
You can take the required speed from the spreading chart.
The setpoint speed is displayed for 10 seconds, after which the actual speed is displayed.

3 Operating the MiniVario®

3.5 Setting the slide opening



If necessary, press the button to select the slide. The arrow points to the second line in the display.

Speed	200
> Slide	29

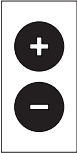

Press the button to adjust the slide opening.
You can take the required slide opening from the spreading chart.

3.6 Opening/closing the slide



Press the button to open or close the slide.
Slide open: green LED lights up
Slide closed: yellow LED lights up

> Speed	200
Slide	29 ok

Slide monitoring

If the slide does not reach the specified position within 10 seconds, the spreader switches off.

The following message is displayed:

Slide not open or **Slide not closed**. 5 warning signals also sound.

Switch off the machine to remedy the fault. For more information, see Troubleshooting chapter.

3 Operating the MiniVario®

3.7 Performing the slide reference run

The slide motor and control panel are adjusted to one another at the factory. The setting can be lost over time or when replacing the control panel.

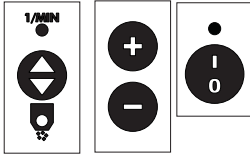

Switch off the machine.

Press and hold down the button for switching between speed and slide and the + button while also pressing the On button for around 3 seconds.

The slide performs its reference run.

Approx. 240 is displayed as the upper value and approx. 40 as the lower value.

Switch off the machine at the main switch; the values are saved.

If a slide reference run cannot be performed, the following message flashes on the display: **slide not calib.**

Check that the slide unit is not blocked by foreign bodies and perform another reference run.

3.8 Setting the spreading width

The spreading width depends on the condition of the spreading material and the speed of the spreading disc. The more coarse the spreading material, the larger the possible spreading width.

The speed and position of the casting shovels should be varied to establish the optimum settings for the various spreading materials.

3 Operating the MiniVario®

3.9 Setting spreading zone

You can set the zone within which the spreading material is to be spread. This allows you to spread the material on one side for example when the carrier vehicle is following the driving line.

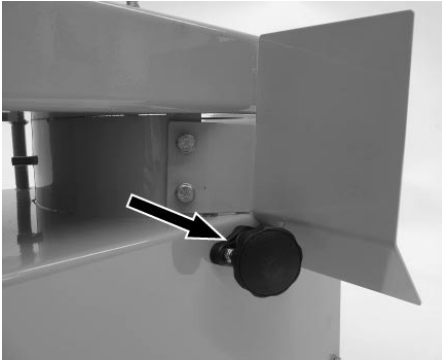

Spread spreading material in left-hand direction of travel
(when mounted at the rear):
turn spindle (arrow) clockwise.

Spread spreading material in right-hand direction of travel
(when mounted at the rear):
turn spindle (arrow) anti-clockwise.

3.10 Empty indicator

The empty indicator shows you when the spreading material in the hopper falls below a specific fill level:
The following message flashes on the display for approx. 5 seconds:
Hopper empty, 8 warning signals sound and the red LED flashes on the empty indicator.

To switch off the empty indicator:
Close the slide or switch off the spreader.

4 Settings and displays

The control element can be used to make the following settings:

- Language
- Empty indicator selection
- EHR signal
- EHR cycle
- Empty indicator adjustment
- Spreader type
- Number of spreaders

4.1 Making settings

Switch off the machine.

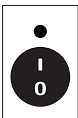
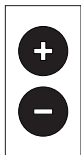

Press and hold down both buttons at the same time while pressing the On button for approx. 3 seconds.

The language selection is displayed.



Press the toggle switch to select the desired menu item.

4.2 Language

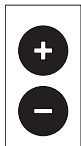

Press the button to set the language.



Press toggle switch: setting saved, next menu item
or
press main switch: setting saved and machine switched off.

4 Settings and displays

4.3 Selecting the empty indicator

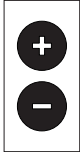

Press the button to select the empty indicator.

Via spreading disc resistance (1),
via mixer motor (2) with soft mixer,
via external empty indicator (3) - not
programmed
or
empty indicator switched off (0).



Press toggle switch: setting saved, next
menu item

or
press main switch: setting saved and
machine switched off.

4.4 Setting signal for electronic lifting gear control (EHR)

When the spreader is equipped with the headline manager accessory, the hydraulic signal of the tractor can be detected. The signal is emitted when lifting or lowering.

The spreader is set at the factory for the signal when lifting.

If the tractor emits the hydraulic signal when lowering, you can adjust the spreader.

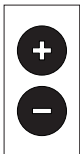

Press the button to set the EHR signal.

EHR signal for lifting:
High active is displayed.
EHR signal for lowering:
Low active is displayed.



Press toggle switch: setting saved, next
menu item

or
press main switch: setting saved and
machine switched off.

4 Settings and displays

4.5 Adjusting the empty indicator

Depending on requirements and spreading material, the empty indicator can be set to respond earlier or later.

The value for the empty indicator to switch on (if the spreading material falls below a certain fill level) can be adjusted from -50 to +50.

Note:

Depending on the spreading material or material humidity, the remainder level may vary somewhat.

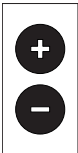

Press the button to set the respective value.

Factory setting is 0.

With + values, the empty indicator responds at a higher fill level.

With - values, the empty indicator responds at a lower fill level.



Press toggle switch: setting saved, next menu item

or

press main switch: setting saved and machine switched off.

4 Settings and displays

4.6 Displaying the spreader type

Control is provided for various spreaders.

The **Polaro**[®] is programmed at the factory as this program is valid for the **MiniVario**[®]



Press toggle switch: setting saved, next menu item
or
press main switch: setting saved and machine switched off.

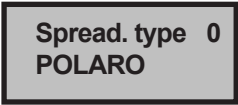

4.7 Headland manager (optional accessory)

If the headline manager is connected, an * is displayed at the end of the first line.



With the headline manager, the slide is automatically opened when lowering the hydraulic and automatically closed when lifting.

The slide can **be manually** opened and closed from the control panel.

The signal can be detected from a 7-pin plug or a sensor signal.

4 Settings and displays

7-pin plug



1. Connect the connecting cable of the control panel to the 7-pin signal plug of the carrier vehicle.
2. Set the EHR signal of the carrier vehicle depending on whether the tractor emits the hydraulic signal when lifting or lowering.

Sensor signal

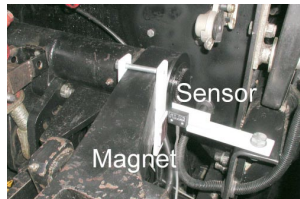

1. Mount the sensor in the joint area of the drift arm.
2. Mount the magnetic sensor to the draft arm.
3. Set position of sensor and magnetic sensor.
Maximum spacing 10 mm.
Hydraulics at bottom:
 sensor not in range of magnetic sensor.
Hydraulics at top:
 sensor just in range of magnetic sensor.
Hydraulics at top:
 sensor must be in range of magnetic sensor.
When raising the hydraulics, the sensor must not exit the magnetic sensor range because otherwise the slide will opened again.

4 Settings and displays

4.8 Controls

Voltage check

To check the operating voltage (in V), the spreader must be on.



Press the toggle switch for 5 seconds.
The operating voltage is displayed for 8 seconds.



Performance check

The motor is set at the factory. No changes are permitted, since otherwise the drive and control parameters no longer match.

To check the performance data, the spreader must be on.



Press the button for min. 5 seconds.
The following information is displayed as long as the button is pressed:
Line 1: current drive motor, power consumption in watts and the exact speed.
Line 2: R value for factory-internal data, the motor voltage in volts, the current consumption of the motor in amps.

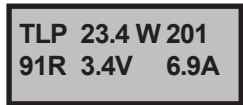

4 Settings and displays

4.9 Spreading width and turning procedure

Turning

1. Put the spreader in the carton or put the carton over the spreader to catch the spreading material.
2. Due to the pull, the speed of the spreading disc used in practice must be set.
3. Weigh out the ejected spreading material at various slide positions until the suitable slide position is determined.

Determining the spreading width

1. Spread on a firm surface.
2. Weigh spreading material or sweep up a swath lateral to the direction of travel and assess the side distribution.

Formulas

$$\frac{\text{g/min} \times 600}{\text{Speed (km/h)} \times \text{spreading width (m)}} = \text{output (g/m}^2\text{)}$$

$$\frac{\text{g/min} \times 600}{\text{Output/m}^2 \text{ (kg)} \times \text{spreading width (m)}} = \text{speed (km/h)}$$

$$\frac{\text{Speed (km/h)} \times \text{output /m}^2 \text{ (g)} \times \text{spreading width (m)}}{600} = \text{g/min}$$

5 Maintenance and cleaning

5.1 Maintenance

Dosing device/slide

The dosing device and slide should be inspected and cleaned at regular intervals depending on use and the spreading material used.

If using very fine spreading material in particular, the slide unit may clog.

	Risk of injury!
Always wear goggles and gloves when using compressed air for cleaning purposes.	

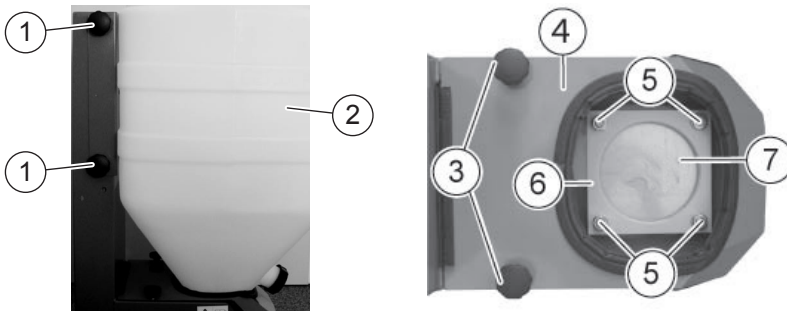

1. Remove mixer plug.
2. Remove knurled screws **1** on the left and right.
3. Remove the hopper **2**.
4. Unscrew knurled screws **3** and take off cover plate **4**.
5. Remove nuts **5**.
6. Dismantle the hopper platform **6** and pull the dosage slide out **7** from the top.
7. Clean the slide unit with a broom or compressed air.
8. Fit parts in reverse order.
Standard lubricant can be applied to the bottom edge to assist with hopper installation.

5 Maintenance and cleaning

Drive motor

The spreading disc's drive motor should be cleaned and greased at the end of the season to extend the motor's service life. Carry out this maintenance work correctly otherwise the manufacturer's warranty may be invalidated.

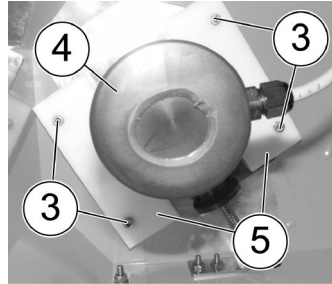
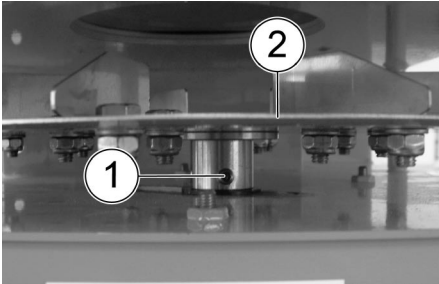

Motor viewed from below

1. Remove mixer plug.
2. Loosen screw **1** on spreading disc **2** and pull spreading disc **2** up and off.
3. Remove plastic washer (thick).
4. Remove screws **3** from below and remove drive motor **4** with spacer and two guide rails **5**.
5. Take plastic washer (thin) off motor shaft.
6. Clean motor shaft and contact surface of plastic washer and apply thin coat of standard copper paste.
7. Fit parts in reverse order.

5.2 Cleaning

The hopper can be almost fully emptied by means of the residual discharge.

1. Unscrew hopper.
2. Clean spreader and hopper with a broom.

6 Appendix

6.1 EC declaration of conformity

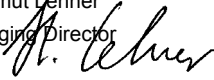
	<p data-bbox="598 272 673 319">CE</p> <p data-bbox="524 327 852 352">EC Declaration of conformity</p> <p data-bbox="296 355 869 378">In accordance with <u>EC Directives 73/23/EEC and 89/336/EEC</u></p> <p data-bbox="296 403 333 426"><u>We.</u></p> <p data-bbox="296 501 524 667">LEHNER GmbH Häuslesäcker 5-9 D-89198 Westerstetten Tel: (+49) 07348/9596-0 Fax: (+49) 07348/9596-40 www.lehner.eu info@lehner.eu</p> <p data-bbox="296 692 441 715">declare that the</p> <p data-bbox="404 775 725 834">MiniVario®</p> <p data-bbox="296 882 975 952">to which this declaration refers complies with the relevant health and safety requirements of EC Directives 9368/EEC and 89/336/EEC and the requirements of the relevant EC Directives.</p> <p data-bbox="575 1002 846 1082">Westerstetten, 20.10.03 Helmut Lehner Managing Director</p>  <p data-bbox="296 1176 975 1214">© This declaration (including extracts hereof) may only be printed with the consent of LEHNER GmbH</p>
---	---

6 Appendix

6.2 Identification

The serial number of the spreader is located on the back of the framework.

Note the serial number in these operating instructions so that it is readily available for inquiries.

The hardware and software versions are briefly displayed when the control panel is connected.

Note the software version in these operating instructions so that it is readily available for inquiries.

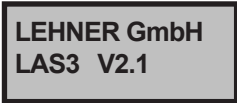

LEHNER GmbH
LAS3 V2.1

6 Appendix

6.3 Distribution box reference list

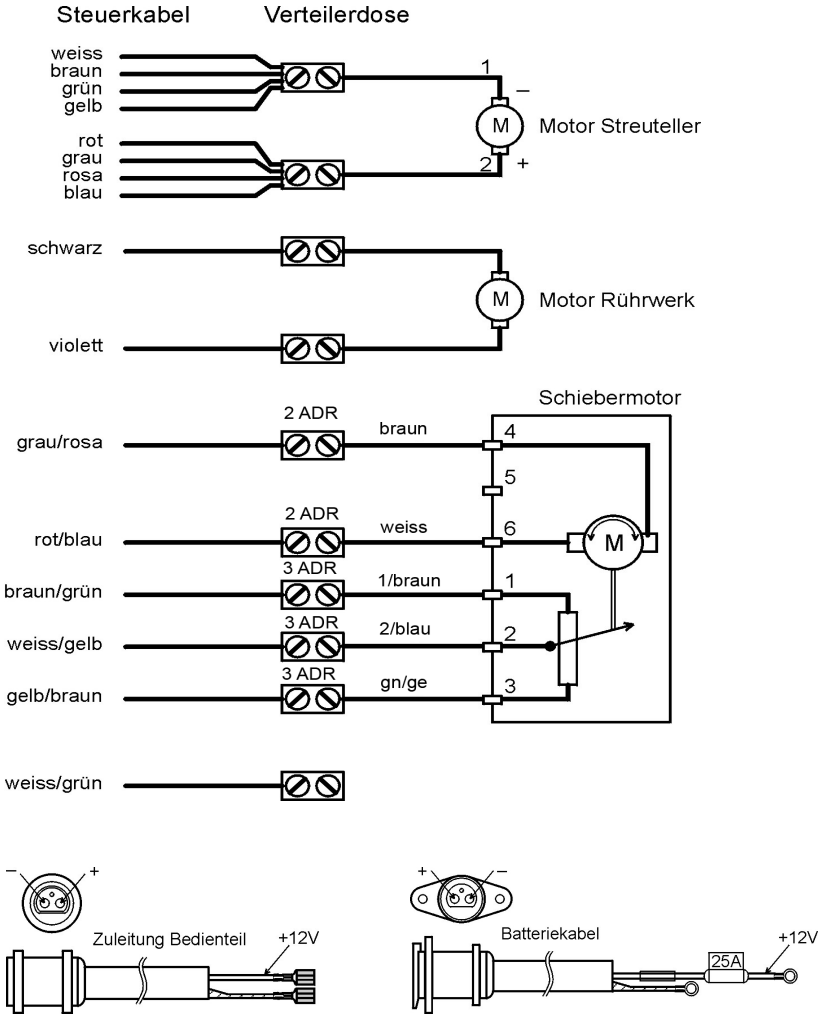

Legend

Steuerkabel	Control cable	Zuleitung Bedienteil	Control panel supply line	gelb	yellow	grau	grey
Verteilerdose	Junction box	Batterie kabel	Battery cable	rot	red	blau	blue
Motor Streuteller	Spreading disc motor	weiss	white	rosa	pink		
Motor Rührwerk	Mixer motor	braun	brown	schwarz	black		
Schiebermotor	Slide motor	grün	green	violett	violet		

6 Appendix

6.4 Troubleshooting

Troubleshooting LEHNER MiniVario® Status: 01/2009

The following information should help you resolve minor problems yourself. You are welcome to call us as needed. We are glad to help.

Problem		Cause		Resolution	
The control panel crackles		Loose contact on the power supply		Check contacts and fuses	
No display		+ and - were switched, fuse is defective		Check connections and fuses	
Spreading disc does not reach set speed		Excess load, motor bearing not running smoothly		Check motor for ease of movement	
Slide jams		Spreading material or dirt has got jammed in the slide		Check slide for foreign bodies and clean	
On the display: Disc blocking		Spreading disc does not turn; switched off after 10 attempts		Check spreading disc Possibly start spreader again	
On the display: Agitator stationary		Agitator does not turn; switched off after 10 attempts Material may be compacted		Check agitator Possibly start spreader again	
On the display: Slide not open		Agitator motor cable not plugged in		Plug in agitator motor cable	
On the display: Slide not closed		Slide could not go into position when opening		Check slide for contamination or perform reference run; see Slide reference run,	
On the display: Slide not closed		Slide could not go into position when closing		Cable not plugged in, motor defective	
On the display: Agitator blocking		Slide could not go into position when closing		Check slide mechanics for foreign body, or perform run; see Slide reference run	
The version is displayed again and again.		Agitator motor has excess power consumption		Empty hopper	
Slide not opening,		Fuse oxidised, loose contact		Check contacts and fuses	
no error message displayed		Mechanical damage to slide mechanics		Check slide motor and mechanics	
On the display: Connecting spr.		Control panel plug not connected to spreader or line damage		Check plug connections and lines Restart machine	
Empty indicator does not respond		Empty indicator is set too low		Adjust empty indicator, see page 21	
Headline manager closes the slide when draining the hydraulics and opens when lifting		Signal incorrectly applied		Change signal. See EHR signal	
Headline manager does not always close		Distance to magnetic sensor too great		Check distance, max. 10 mm.	

6 Appendix

6.5 Parts list

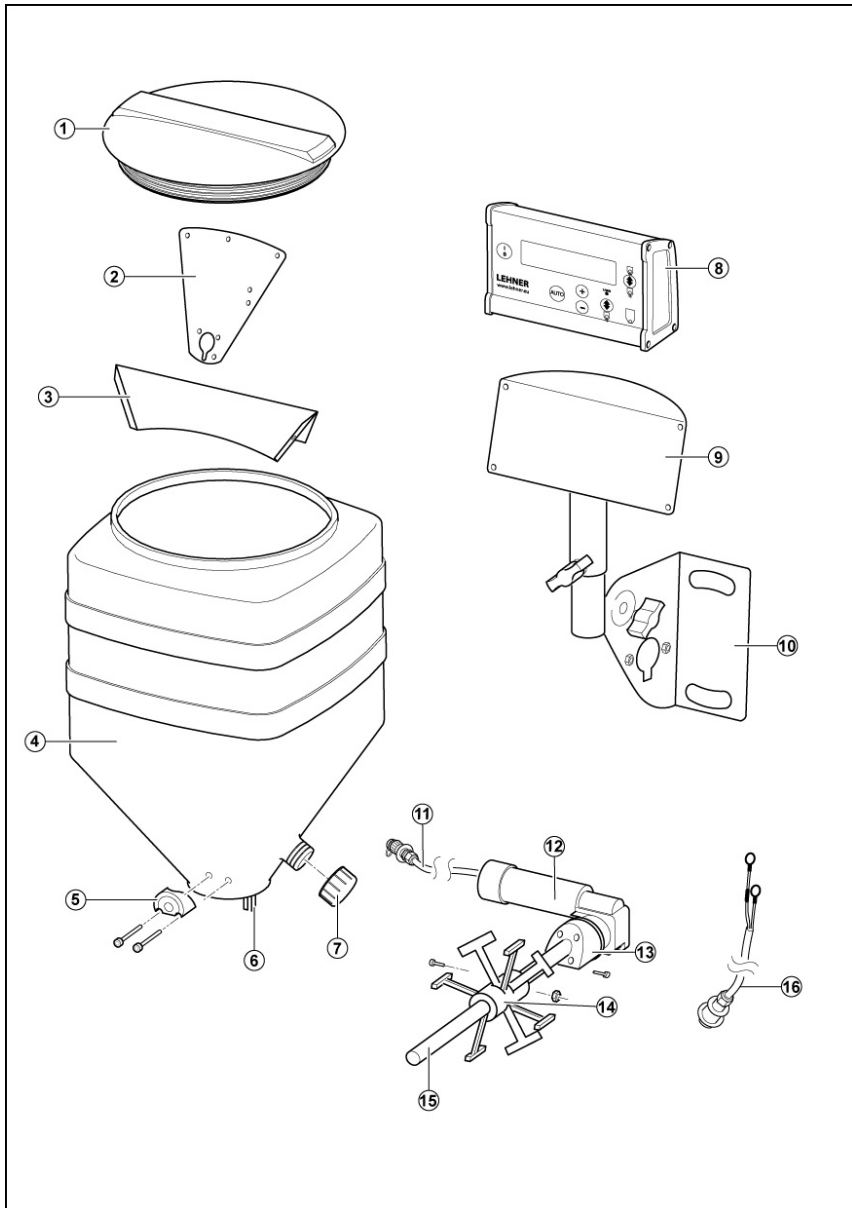

6 Appendix

6.5 Parts list

	Designation	Quantity	Material	Size
1	Sealing cap	1	Plastic	
2	Reinforcement plate	1	VA	
3	Load relief roof	1	VA	
4	Hopper	1	Plastic	70/105/170 ltr.
5	Counter bearing for agitator	1	Plastic	
6	Extra hopper bracket	1	VA	
7	Discharge cover	1	Plastic	
8	Control panel	1		
9	Upper part of bracket	1	Steel	
10	Lower part of bracket	1	Steel	
11	Plug with cable for mixer motor	1		
12	Mixer motor	1		
13	Agitator bearing with lubricating nipple	1	Plastic	
14	Agitator	1	Steel	
15	Agitator	1	VA	70/105/170 ltr.
16	Battery cable with bracket	1		

6 Appendix

6.5 Parts list

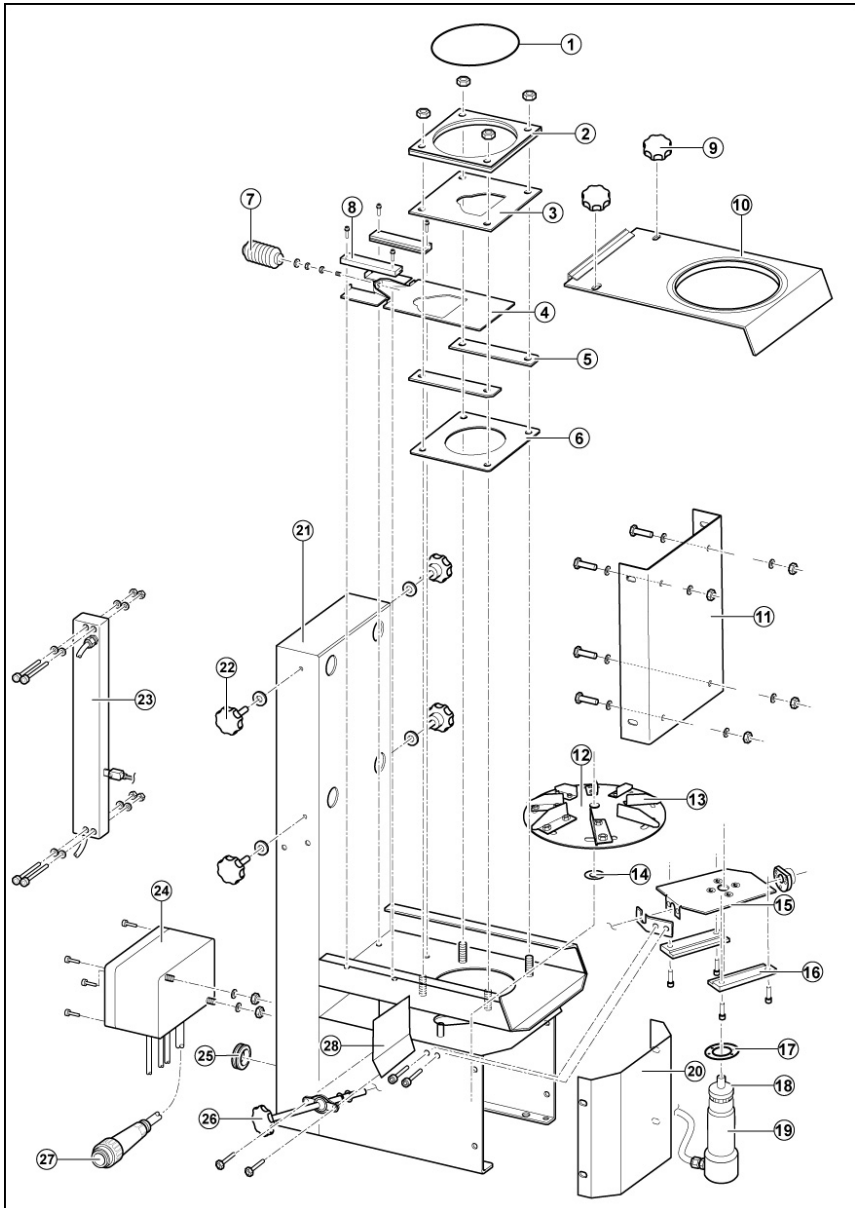

6 Appendix

6.5 Parts list

	Designation	Quantity	Material	Size
1	Hopper seal	1	Rubber	
2	Hopper platform	1	Plastic	150X150X15
3	Dosage slide, top	1	VA	150X150X2
4	Slide	1	VA	
5	Slide guide	2	VA	2.5 mm
6	Dosage slide at bottom	1	Plastic	150X150X2
7	Gaiter	1	Plastic	
8	Slide guide	2	Plastic	
9	Star grip nut	2	Plastic / VA	M 6
10	Cover plate with seal	1	VA/rubber	
11	Hopper bracket	1	VA	70/105/170 ltr.
12	Spreading disc	1	VA	
13	Casting shovel	8	VA	
14	Washer	1	Plastic	40X12X1.2
15	Motor support (movable)	1	VA	
16	Motor support guide rail	2	Plastic	
17	Spacer	1	VA	4 mm
18	Sealing disc for motor	1	Plastic	
19	Drive motor	1		
20	Front plate	1	VA	
21	Frame	1	VA	
22	Star-knob screw	4	Plastic / VA	M 8
23	Chain motor	1		
24	Distributor box	1		
25	Cable protection sleeve	1	Rubber	
26	Motion spindle	1	Plastic / VA	
27	Control cable with plug	1		6m/11m
28	Deflector plate	1	VA	